

EXPERIMENTAL AND NUMERICAL ISSUES IN THE MODELLING OF THE MECHANICAL BEHAVIOUR OF MASONRY

P.B. Lourenço
University of Minho
Department of Civil Engineering
Azurém
P-4800 Guimarães
PORTUGAL

SUMMARY

In the last forty years an enormous growth in the development of numerical tools for structural analysis has been achieved. The use of such tools demands advanced testing in order to obtain the experimental characterisation of the mechanical behaviour of materials. This paper provides a review of displacement controlled experimental results and set-ups carried out in the last decade that are relevant for the purpose of sophisticated numerical modelling of masonry. The review includes testing under tension, shear and compression of units, mortar and small masonry samples, as well as, testing of masonry panels under uniaxial tension, uniaxial compression and biaxial stresses.

An overview of possible approaches for the numerical modelling of masonry structures is also presented. This includes independent modelling of the units and joints, as well as modelling of masonry as an anisotropic continuum. Finally, recently developed sophisticated models and examples of their application are briefly presented.

1. INTRODUCTION

Masonry is the oldest building material that still finds wide use in today's building industries. The most important characteristic of masonry construction is its simplicity. Laying pieces of stone, bricks or blocks on top of each other, either with or without cohesion via mortar, is a simple, though adequate, technique that has been successfully used ever since remote ages. Naturally, innumerable variations of masonry

materials, techniques and applications occurred during the course of time. The influence factors were mainly the local culture and wealth, the knowledge of materials and tools, the availability of material and architectural reasons.

The decay of masonry as a structural material and the lack of standardisation of the material resulted in a lack of resources used for masonry research. This applies both for new and old masonry structures. Time shows that many historical constructions have collapsed. Europe possesses notorious examples, like the ones related to the earthquake of Lisbon in 1755, where dozens of monuments and hundreds of constructions crumbled. Nevertheless, not only exceptional events affect historical constructions. Fatigue and strength degradation, accumulated damage due to traffic, wind and temperature loads, soil settlements and the lack of structural understanding of the original constructors are high risk factors for the architectural heritage.

Recent examples of irreversible losses of the cultural and architectural damage can be found, for example, in Italy: Campanile of St. Marcus in Venice (total collapse in 1902 after being repeatedly struck by lightning), Civic Tower of Pavia (total collapse in 1989 with hardly any warning) and Cathedral of Noto (collapse of the dome in 1996). Famous examples of historical constructions in risk due to soil settlements are the Cathedral of Mexico City and the tower of Pisa, and constructions in risk due to a deficient structural conception are the Cathedral of Pavia and the Cathedral of Florence.

Nevertheless, only very recently the scientific community began to show interest in advanced testing (under displacement control) and advanced tools of analysis for historical constructions. The lack of experience in this field is notorious in comparison with more advanced research fields like concrete, soil, rock or composite mechanics. In this paper, it is shown that a complete set of displacement controlled tests can be carried out, in order to obtain the properties necessary for advanced numerical models. It is also advocated that sophisticated and robust models for masonry structures are currently available and can be successfully used for the analysis of historical constructions.

1.1 Masonry through time

It is about ten thousand years ago, with the earliest civilisation, that the history of architecture really begins and simultaneously masonry arises as a building technique. The primitive savage endeavours of mankind to secure protection against the elements and from attack included seeking shelter in rock caves, learning how to build tents of bark, skins, turves or brushwood and huts of wattle-and-daub. Some of such types crystallised into houses of stone, clay or timber. The evolution of mankind is thus linked to the history of architecture, e.g. [1], and the history of building materials, see e.g. [2].

The first masonry material to be used was probably stone. In the ancient Near East, evolution of housing was from huts, to apsidal houses (Figure 1a), and finally to rectangular houses (Figure 1b). The earliest examples of the first permanent houses can be found near Lake Hullen, Israel (*c.* 9000-8000 BC), where dry-stone huts, circular and semi-subterranean, were found. Several other legacies survived until present as testimonies of ancient and medieval cultures, for instance, the Egyptian architecture with its pharaonic pyramids (*c.* 2800-2000 BC), the massive Roman and Romanesque architecture (*c.* AD 0-1200) with its temples, palaces, arches, columns, churches, bridges and aqueducts, the Gothic architecture (*c.* AD 1200-1600) with its magnificent cathedrals and many others, see Figures 2 to 4.

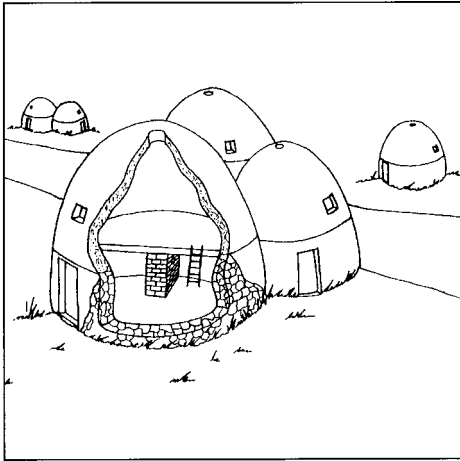

(a)

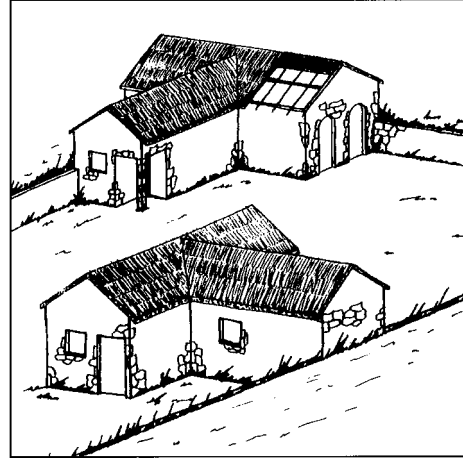

(b)

Figure 1 - Examples of prehistoric architecture of masonry in the ancient Near East: (a) beehive houses from a village in Cyprus (c. 5650 BC); (b) rectangular dwellings from a village in Iraq.

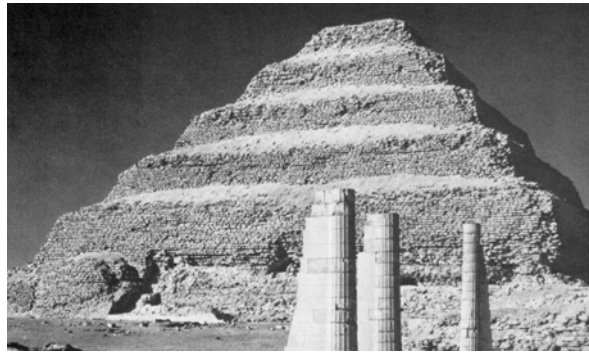

(a)

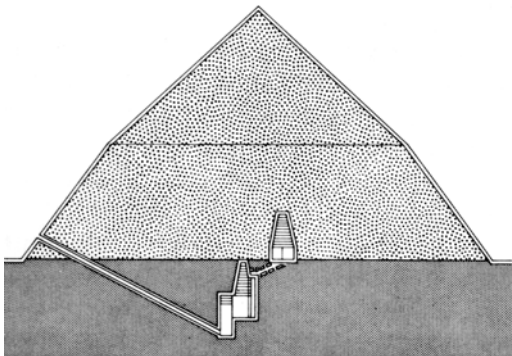

(b)

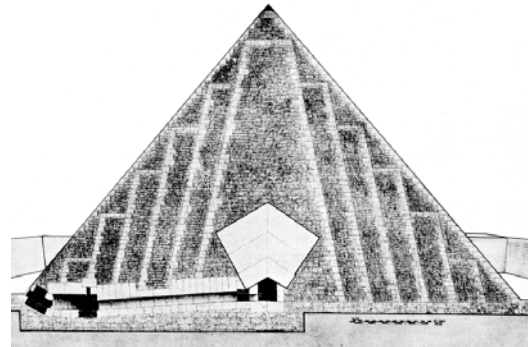

(c)

Figure 2 - The adaptive process of building pyramids in ancient Egypt: (a) the Step Pyramid of Zoser at Saqqara (c. 2675 BC) is constructed round an earlier flat massif formed of horizontal blocks of masonry; (b) the Bent Pyramid of Sneferu at Dahshur (c. 2600 BC) was started with a slope of 52° and continued at the safer angle of 43.5° . It is formed of horizontal blocks overlaid with a gently-inclined facing; (c) the Pyramid of Sahura (c. 2500 BC) design was adopted in all other pyramids of the Old Kingdom (including the highest built Pyramid of Cheops with 160 m).

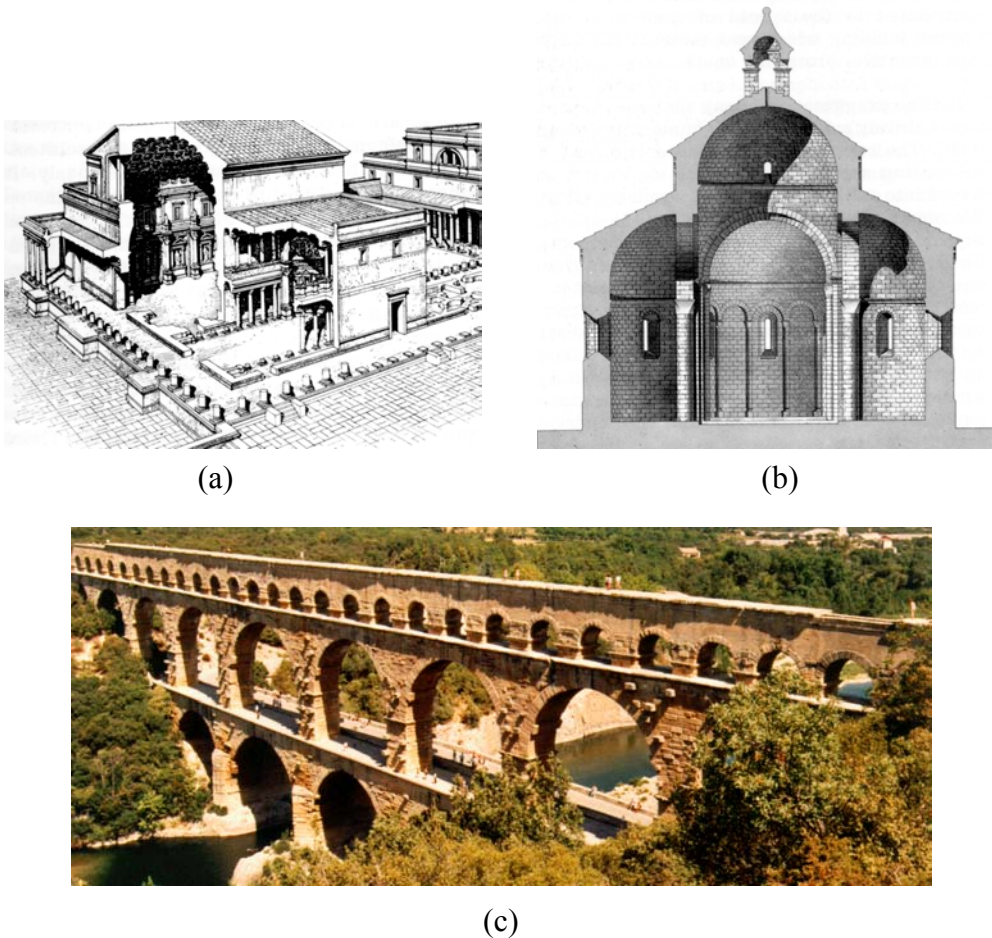

Figure 3 - The massive Roman Style: (a) Domus Flavia, Rome, Italy (completed in AD 92) shows the massive walls and small openings associated with poor structural knowledge and experience; (b) Church in Gensac-la-Pallue, France (twelfth-century) shows that the massive style survived until late; (c) the 290 m long aqueduct Pont du Gard, Nîmes, France (c. AD 14) is well preserved and formed of three tiers of arches, crossing the valley 50 m above the river. Except for the top tier, the masonry was laid dry.

The first assault to the use of structural masonry happened at the middle of the nineteenth-century, when cast-iron beams and columns started to be produced. By the end of the century, skyscraper constructions methods had eliminated the necessity of massive ground-level piers of masonry. Nevertheless, the collapse of masonry as a structural material started in the beginning of the twentieth-century, with the introduction of German, French and British regulations for design of reinforced concrete structures. Concrete was used in constructions of walls as early as the fourth-century BC around Rome. But, only in 1854, a system for reinforced concrete was patented in Britain by W.B. Wilkinson. By the beginning of the twentieth-century it was clear that reinforced concrete was a durable, strong, mouldable and inexpensive material, and masonry was practically forgotten as a structural material in most countries.

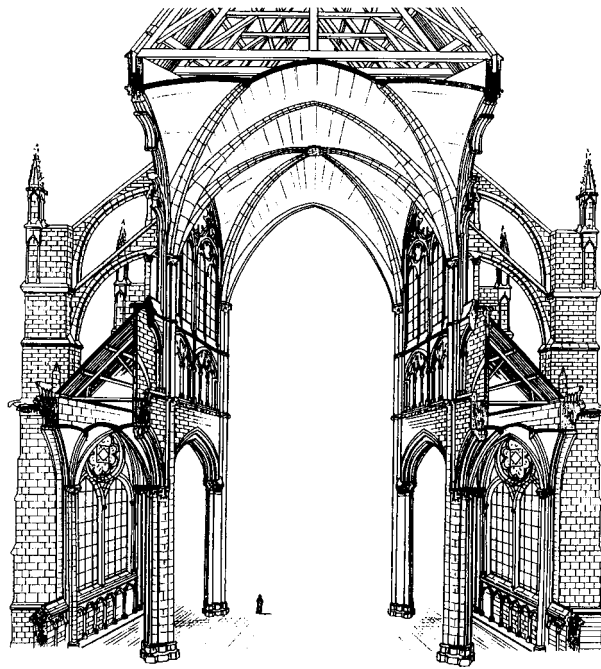

Figure 4 - Transverse section of a typical Gothic cathedral, Amiens, France (1220-1288). The collected load of the nave vaulting has a downward component due to its own weight and a horizontal component due to the arched form of the vault, which are carried, respectively, by a system of columns and massive buttresses weighted by pinnacles.

Moreover, the evolution of old building techniques into new and modern applications occurred unsuccessfully. Presently, prejudices persist against structural masonry, based on the claim that it is expensive, fragile, unable to withstand earthquakes and dependent on unreliable workmanship and unknown quality. As a consequence, only few resources have been put in structural masonry research both for new materials and existing heritage, the current codes of practice are underdeveloped and there is a lack of knowledge about the behaviour of this composite material. Recently, a number of initiatives funded by National or European Institutions, see [3] for a review, and the industry has directed the interest of researchers towards new and old masonry. Still, there is a lack of knowledge on important issues like non-destructive testing, experimental behaviour, numerical modelling and retrofitting, meaning that past mistakes can be repeated. Unfortunately, research progress has also been hindered by the lack of communication between analysts and experimentalists.

1.2 Structural Analysis Through Time (“Ars sine scientia nihil est”)

Structural design must balance the realities of construction practices and the discipline of structural engineering. The former is largely empirical, based on experience gained in building and the skills of the building crafts. The latter, usually expressed in mathematical terms, is founded on theoretical knowledge, experience and the profession’s responsibility for public safety. With this last concern, the wisdom of the engineer and decisions of governmental institutions define load values as well as partial safety factors for loads and materials. Therefore, structural engineering can be

seen as an “empirical technology” that combines theoretical investigations, data and social responsibilities in design.

No such complexity is to be found in ancient times, when empirical knowledge of building crafts, taught by master to apprentices, provided the tradition and theory on which structural design was based. The Roman architect Vitruvius in his Ten Books of Architecture [4] compared the qualities of stone taken from different quarries and the wood of different trees. Although he wrote at length about the traditional proportions of columns and the spaces between them, little was said of structural considerations, except for a declaration that in one style of temple (araeostyle) columns were spaced “farther apart than they ought to be”.

Medieval masons during their apprenticeship were introduced to the geometrical techniques required to lay out plans and prepare the templates and models from which stonework would be cut. The traditional methods and rules-of-thumb of their craft were imparted to them as part of the mysteries of the mason’s lodge and all guild members were sworn secrecy.

The transformation of the massive stonework of Romanesque architecture into the delicate tracery of the Gothic presents clear evidence of the powerful logic of the trial and error methods employed by the medieval builders. Without mathematical theories or predictive methods, but with great geometrical skill, Gothic builders learned to fashion stone - a material limited to receiving compressive forces and requiring careful fitting - into ribs and vaults that display some understanding of the actions of forces within the structure. The walls enclosed, but did not support, the structure, consisting, mainly, of glazed windows. This skeleton of piers, buttresses, arches and ribbed vaulting can be considered the splendour of the art of cutting stone, that looks at once dangerously fragile for its size and heavy enough to defy all the laws of structural stability. To modern eyes, it is a breathtaking triumph of skill over probability.

The documentary evidence from the cathedral of Troyes and Milan disconcertingly shows that any coherent advanced plan was in practice ignored, and medieval buildings could apparently withstand substantial alterations to the fabric both during construction and after an interval of many years, see [5]. Not only the “design” could be refined as the construction proceeded but also radical assaults could be made to the structure, with changes in height and proportions when it was already half-built.

How much of the structural behaviour was known to masons is one of the most tantalising questions because it cannot be definitely answered. Little has been discovered to indicate medieval knowledge of elementary engineering as it is known today, and it is evident that builders of that period did not employ any form of structural analysis. Medieval masons had no means of calculating the amount of buttressing required by any particular design, and seem to have discovered the margins of safety through observation and experience; they were additionally fortunate in that the proportions to which they built happened to lie in the necessary limits of stability. Their tendency was, if anything, to err on the side of safety and provide more buttressing than engineers now know to be necessary. Surviving records reveal that both patrons and masons became deeply anxious about structural questions. It was quite usual to hold an ‘Expertise’, that is, a conference comprising a number of outside masters, to inspect and advise on faults that had developed in old buildings or in a new building campaign that seemed to be going awry. At the most famous Expertise of all, held at Milan, around 1400, questions of structure and proportion are inextricably linked; if a building was proportionately correct (if it had the “right measure”), it would be structurally correct.

Successive northern masters came to act as consultants and were rapidly dismissed or left on their own. The fourth and last consultant (Jean Mignot) delivered the aphorism that made him immortal: *Ars sine scientia nihil est*. By this he meant that the practice (ars) of masonry is nothing without the theoretical knowledge (scientia), in this case the geometry. As far as Mignot was concerned the technical and the aesthetic were one. The rules themselves, however, remain obstinately vague. The only comparable rule is that of the correct thickness of the buttress in proportion to the pier: Mignot says it should be 3:1, but the treatise of Gil de Hontañon gives 4:1 and the Milanese claimed that 1.5:1 was sufficient because local marble was stronger than northern limestone. There was evidently no more rational basis for any of these opinions. But through experience with the actual performance of a relatively small group of structural elements (arches, vaults, ribs, buttresses and counterweights), an impressive empirical wisdom was achieved. Still, a degree of prediction was furnished by the building process. When famine, plague, warfare, lack of funds halted the construction of a cathedral the stonework settled through the years it waited for work to be resumed. The appearance of cracks or spalling of stone indicated incipient danger and corrections were made.

While craft traditions had sufficed for the remarkable traceries of the Gothic construction, theoretical explanations were sought in the Renaissance, see [6]. Leonardo da Vinci could have been the first to contend that the thrust followed a path that remained within the arch, but much of the lengthy study that commenced in the Renaissance focused on the construction of domes. In experiments, chains were draped to represent the curves that might be the inverted lines of thrusts and intricate graphic solutions attempted to follow forces from stone to stone. Long after Leonardo, in 1586, Simon Stevinus published a book on statics; its translation to Latin in 1608 as “*Mathematicorum Hypomnemata de Statica*” made his knowledge accessible to scientists and mathematicians throughout Europe, and provided the basis for nineteenth century in graphic statics, which enabled the solution of structural problems through drawings.

1.3 Modern Structural Analysis and Masonry (“Ut tensio sic vis”?)

The finite element method is usually adopted to achieve sophisticated simulations of the structural behaviour. A mathematical description of the material behaviour, which yields the relation between the stress and strain tensor in a material point of the body, is necessary for this purpose. This mathematical description is commonly named a constitutive model. Constitutive models of interest for practice are normally developed according to a phenomenological approach in which the observed mechanisms are represented in such a fashion that simulations are in reasonable agreement with experiments. It is not realistic to try to formulate constitutive models which fully incorporate all the interacting mechanisms of a specific material because any constitutive model or theory is a simplified representation of reality. It is believed that more insight can be gained by tracing the entire response of a structure than by modelling it with a highly sophisticated material model or theory which does not result in a converged solution close to the failure load. An important objective of today’s research is thus to obtain robust numerical tools, capable of predicting the behaviour of the structure from the linear elastic stage, through cracking and degradation until complete loss of strength. Only then, it is possible to control the serviceability limit state, to fully understand the failure mechanism and assess the safety of the structure.

The last decades have witnessed an enormous development in numerical methods and programs of structural analysis. Today, with the help of a computer, it is possible to analyse structures with a high level of accuracy. The material science (directly dependent on the observation and analysis of the experimental behaviour) has suffered a slower evolution but, in the last years, important advances in constitutive models have occurred in various fields. It is striking that these advances are strongly dependent on the co-operation between experimentalists and analysts.

In the education of structural engineers, much emphasis is given to mechanics, statics and computational methods but very little emphasis has been given to material science. This means that the use in practice of adequate material behaviour in structural analysis did not keep the pace with the corresponding scientific development. For this reason, in today's structural analysis, the constitutive model usually determines its the level of accuracy, see Figure 5. New numerical methods and new analysis capabilities have been absorbed in the practice of structural engineering (even if not always in an adequate form), but material mechanics has not.

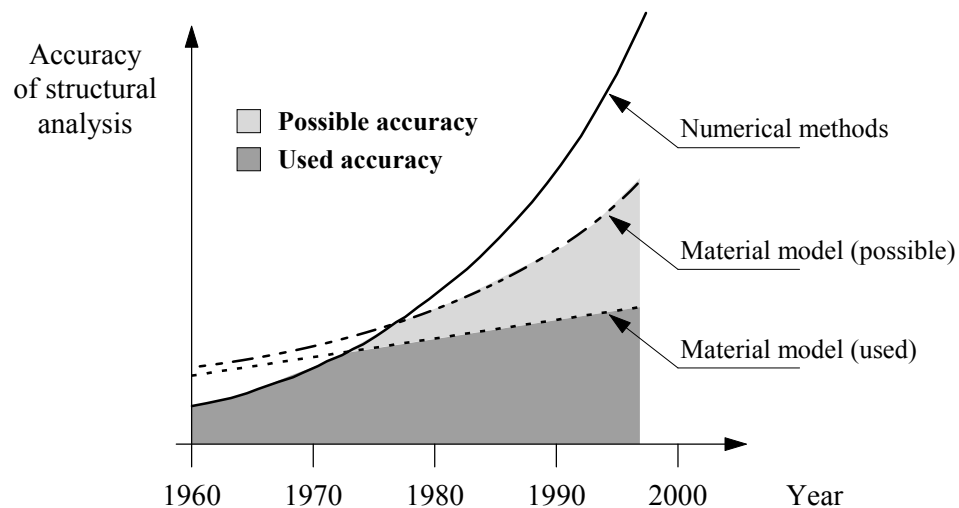

Figure 5 - Accuracy of structural analysis through time.

“Ut tensio sic vis” (‘as the extension, so the force’), or $\sigma / E = \varepsilon$, is the fundamental law of elasticity proposed by R. Hooke in 1676 in the anagram “ceiinosstuv”. The mathematical theory of elasticity was firmly established in the nineteenth century and did not lose its importance until today. This elasticity law for homogeneous materials is the most used constitutive model adopted by structural engineers to obtain an estimate of the structural response and collapse loads. Even if safety factors, based on the experience and experimental testing, are adopted for the calculations, structural engineers have regularly failed to evaluate correctly the behaviour of complex structures, which have led to inaccuracies in assessing their safety and to some catastrophic structural accidents.

In the case of masonry structures, the problem is somewhat more complicated as described in the previous Section. Very little advanced research on numerical modelling of masonry structures has been carried out. At the present stage of knowledge, numerical simulations are fundamental to provide insight into the structural behaviour and to assess/retrofit existing masonry structures. Nevertheless, the step towards the

development of reliable and accurate numerical models cannot be performed without a thorough material description and a proper validation by comparison with a significant number of experimental results. This means that carefully, deformation controlled, experiments in large-scale masonry tests, small masonry samples and masonry components are necessary. Recently discovered properties, like softening and dilatancy, being virtually absent in the masonry literature, play a crucial role in the inelastic processes. A combined experimental/numerical basis is the key to validate, extend and improve existing methods.

It is obvious that not all the research work can and will be used in practice (at least, in a short term). The problems related to the analysis of ancient constructions are gigantic: the geometry is usually missing, the constitution of the inner core of the structural elements is unknown, a complete mechanical characterisation of the materials utilised is hardly possible, the sequence of construction is not documented and the building processes vary substantially from one period to another as well as from one site to another. Nevertheless, it is believed that sophisticated numerical tools are of capital importance for the process of building knowledge about the structural behaviour of the constructions and for sensitivity studies about material parameters. Once the appropriate level of confidence and the understanding of the main influence factors in the simulations are achieved, the analysts will be able to adopt the simplifications necessary to make the calculations with the required safety factors.

Only recently did the masonry research community begin to show interest in sophisticated numerical tools as an opposition to the prevailing tradition of rules-of-thumb and empirical formulae. The fact that little importance has been attached to numerical aspects is confirmed by the absence of well established models for describing masonry behaviour. The difficulties in adopting existing numerical tools from more advanced research fields are hindered by the particular characteristics of masonry.

For the above reasons, attention will be devoted here to the discussion of a comprehensive set of experimental tests which are necessary for numerical simulations. In this sense, the current paper can be considered a sequel of [7] in the previous Seminar, even if it can be read as a separate paper in its own right. Therefore, a certain amount of repetition has been unavoidable.

2. “COMPLETE¹” DESCRIPTION OF MASONRY

Masonry is a heterogeneous material that consists of units and joints. Units are such as bricks, blocks, ashlars, adobes, irregular stones and others. Mortar can be clay, bitumen, chalk, lime/cement based mortar, glue or other. A (very) simple classification of stone masonry is shown in Figure 6. The huge number of possible combinations generated by the geometry, nature and arrangement of units as well as the characteristics of mortars raises doubts about the accuracy of the term “masonry”. Just for brick masonry, some usual combinations are shown in Figure 7.

¹ The word *complete* is used here in the sense that the description of masonry includes the material data necessary for advanced non-linear numerical calculations. The author is aware that for other purposes, e.g. the compressive strength of masonry might be a *complete* description.

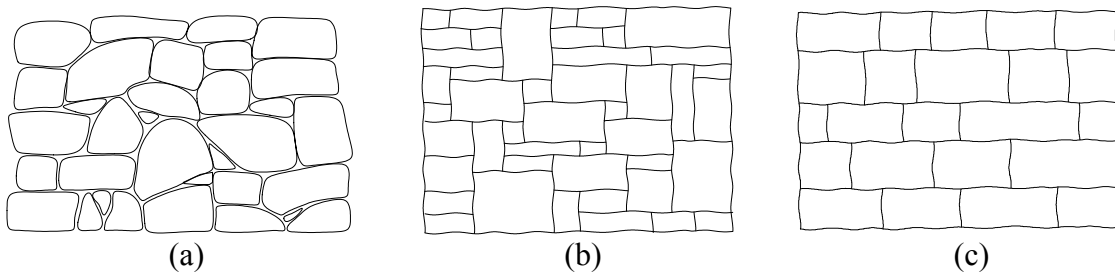

Figure 6 - Different kinds of stone masonry: (a) rubble masonry; (b) ashlar masonry; (c) coursed ashlar masonry.

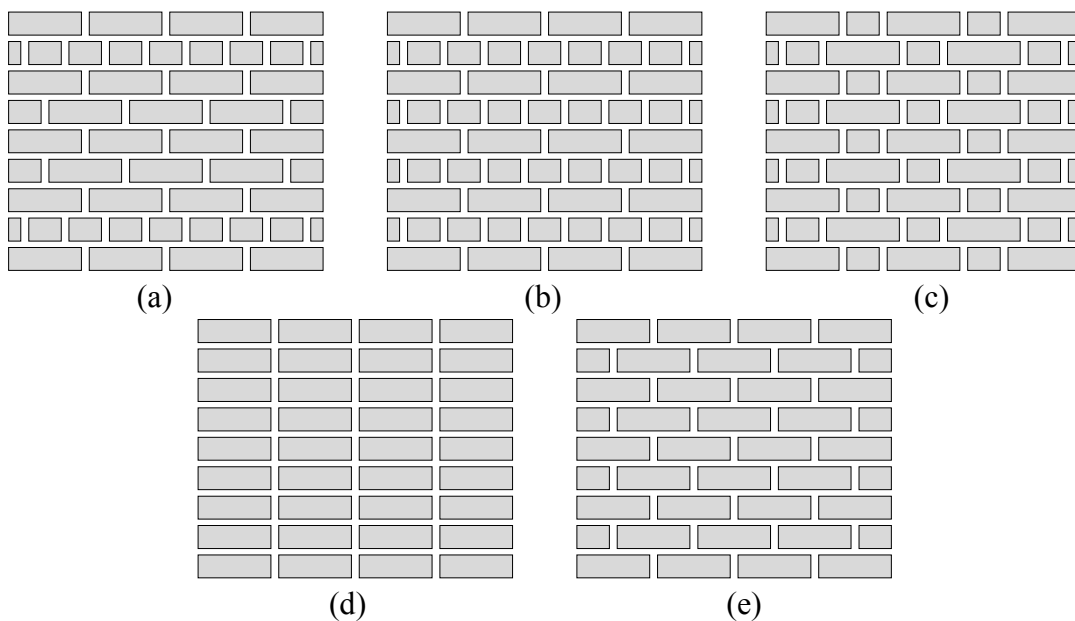

Figure 7 - Different arrangements for brick masonry: (a) American (or common) bond; (b) English (or cross) bond; (c) Flemish bond; (d) stack bond; (e) stretcher bond.

When the walls of ancient constructions were of small width, stone units could be of the full width (bond stone or through stone). If the walls were very thick, ashlar would only be used for the outer leafs and the inside would be filled with irregular stones or rubble, or more than one leaf of masonry would be used, see Figure 8.

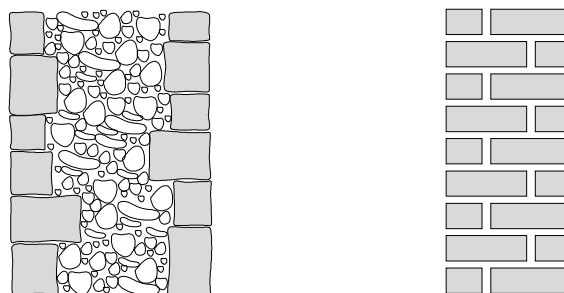

Figure 8 - Possible cross section of thick masonry walls.

Nevertheless, the mechanical behaviour of the different types of masonry has generally a common feature: a very low tensile strength. This property is so important that it has determined the shape of ancient constructions. The difficulties in performing advanced testing of ancient structures are quite large due to the innumerable variations of masonry, the variability of the masonry itself in a specific structure and the impossibility of reproducing it all in a specimen. Therefore, most of the advanced experimental research carried out in the last decade has concentrated in brick / block masonry and its relevance for design. This greater interest is reflected next, even if what will be described can be applied to any masonry type, or other materials in which bonding, cohesion and friction between constituents form the basic mechanical actions.

The paper concentrates in plane stress mechanical behaviour, that can be satisfactorily adopted to represent plates (walls) and shells (domes, vaults, etc.), being, therefore, sufficiently accurate for the analysis of most historical constructions. Importance is given here to displacement controlled test configurations capable of capturing the entire load-displacement diagram. In particular, attention is given to an integrated experimental and numerical research program completed in the Netherlands and reported in [8]. A complete description of the material is not pursued in this study and the reader is referred to [9,10] for this purpose.

2.1 Overview of strategies for the numerical modelling of masonry structures

Masonry is a material which exhibits distinct directional properties due to the mortar joints which act as planes of weakness. In general, the approach towards its numerical representation can focus on the micro-modelling of the individual components, viz. unit (brick, block, etc.) and mortar, or the macro-modelling of masonry as a composite, see also [11]). Depending on the level of accuracy and the simplicity desired, it is possible to use the following modelling strategies, see Figure 9:

- Detailed micro-modelling - units and mortar in the joints are represented by continuum elements whereas the unit-mortar interface is represented by discontinuous elements;
- Simplified micro-modelling - expanded units are represented by continuum elements whereas the behaviour of the mortar joints and unit-mortar interface is lumped in discontinuous elements;
- Macro-modelling - units, mortar and unit-mortar interface are smeared out in the continuum.

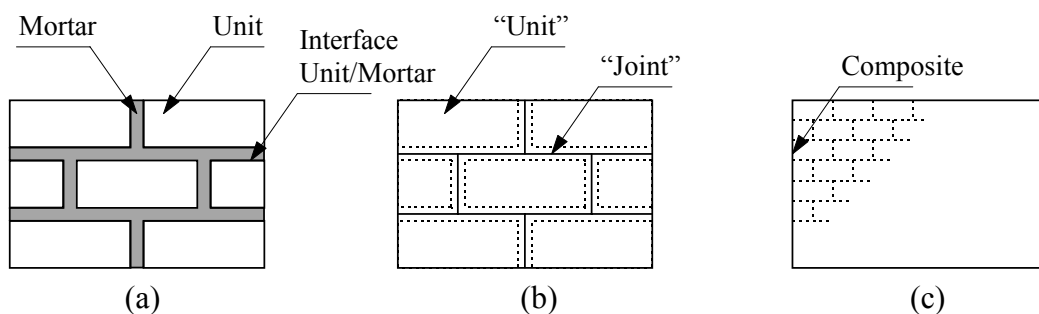

Figure 9 - Modelling strategies for masonry structures: (a) detailed micro-modelling; (b) simplified micro-modelling; (c) macro-modelling.

In the first approach, Young's modulus, Poisson's ratio and, optionally, inelastic properties of both unit and mortar are taken into account. The interface represents a potential crack/slip plane with initial dummy stiffness to avoid interpenetration of the continuum. This enables the combined action of unit, mortar and interface to be studied under a magnifying glass. In the second approach, each joint, consisting of mortar and the two unit-mortar interfaces, is lumped into an average interface while the units are expanded in order to keep the geometry unchanged. Masonry is thus considered as a set of elastic blocks bonded by potential fracture/slip lines at the joints. Accuracy is lost since Poisson's effect of the mortar is not included. The third approach does not make a distinction between individual units and joints but treats masonry as a homogeneous anisotropic continuum. One modelling strategy cannot be preferred over the other because different application fields exist for micro- and macro-models. Micro-modelling studies are necessary to give a better understanding about the local behaviour of masonry structures. This type of modelling applies notably to structural details, but also to modern building systems like those of concrete or calcium-silicate blocks, where window and door openings often result in piers that are only a few block units in length. These piers are likely to determine the behaviour of the entire wall and individual modelling of the blocks and joints is then to be preferred. Macro-models are applicable when the structure is composed of solid walls with sufficiently large dimensions so that the stresses across or along a macro-length will be essentially uniform. Clearly, macro-modelling is more practice oriented due to the reduced time and memory requirements as well as a user-friendly mesh generation. This type of modelling is most valuable when a compromise between accuracy and efficiency is needed.

Accurate micro- or macro-modelling of masonry structures requires a thorough experimental description of the material. Obtaining experimental data, which is reliable and useful for numerical models, has been hindered by the lack of communication between analysts and experimentalists. The use of different testing methods, test parameters and materials preclude comparisons and conclusions between most experimental results. It is also current practice to report and measure only strength values and to disregard deformation characteristics. In particular, for the post-peak or softening regime (see next Section for a complete definition) almost no relevant information has been available in the literature.

2.2 Aspects of softening behaviour

Softening is a gradual decrease of mechanical resistance under a continuous increase of deformation forced upon a material specimen or structure. It is a salient feature of quasi-brittle materials like clay brick, mortar, ceramics, rock or concrete, which fail due to a process of progressive internal crack growth. Such mechanical behaviour is commonly attributed to the heterogeneity of the material, due to the presence of different phases and material defects, like flaws and voids. Even prior to loading, mortar contains micro-cracks due to the shrinkage during curing and the presence of the aggregate. The clay brick contains inclusions and micro-cracks due to the shrinkage during the burning process. Stone also, usually, contains inclusions and micro-cracks. The initial stresses and cracks as well as variations of internal stiffness and strength cause progressive crack growth when the material is subjected to progressive deformation. Initially, the micro-cracks are stable which means that they grow only when the load is increased. Around peak load an acceleration of crack

formation takes place and the formation of macro-cracks starts. The macro-cracks are unstable, which means that the load has to decrease to avoid an uncontrolled growth. In a deformation controlled test the macro-crack growth results in softening and localisation of cracking in a small zone while the rest of the specimen unloads.

For tensile failure this phenomenon has been well identified, see e.g. [12]. For shear failure, a softening process is also observed as degradation of the cohesion in Coulomb friction models. For compressive failure, softening behaviour is highly dependent upon the boundary conditions in the experiments and the size of the specimen [13,14]. Experimental concrete data provided in [14] indicated that the behaviour in uniaxial compression is governed by both local and continuum fracturing processes.

Figure 10 and Figure 11 show characteristic stress-displacement diagrams for quasi-brittle materials in uniaxial tension and compression. In the present study, it is assumed that the inelastic behaviour both in tension and compression can be described by the integral of the $\sigma - \delta$ diagram. These quantities, denoted respectively as fracture energy G_f and compressive fracture energy G_c , are assumed to be material properties.

With this energy-based approach tensile and compressive softening can be described within the same context which is plausible, because the underlying failure mechanisms are identical, viz. continuous crack growth at micro-level. It is noted that masonry presents other type of failure mechanism, generally identified as mode II, that consists of slip of the unit-mortar interface under shear loading, see Figure 12. Again, it is assumed that the inelastic behaviour in shear can be described by the mode II fracture energy G_f^II , defined by the integral of the $\tau - \delta$ diagram in the absence of normal confining load. Shear failure is a salient feature of masonry behaviour which must be incorporated in a micro-modelling strategy. However, for continuum models, this failure cannot be directly included because the unit and mortar geometries are not discretised. Failure is then associated with tension and compression modes in a principal stress space.

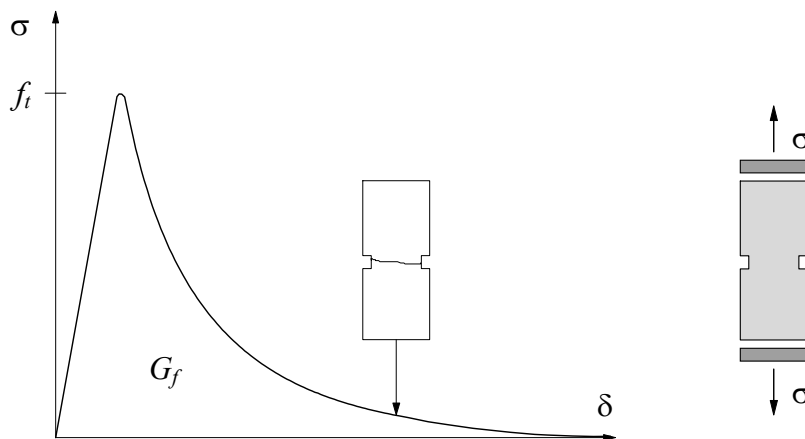

Figure 10 - Typical behaviour of quasi-brittle materials under uniaxial tension and definition of fracture energy (f_t denotes the tensile strength).

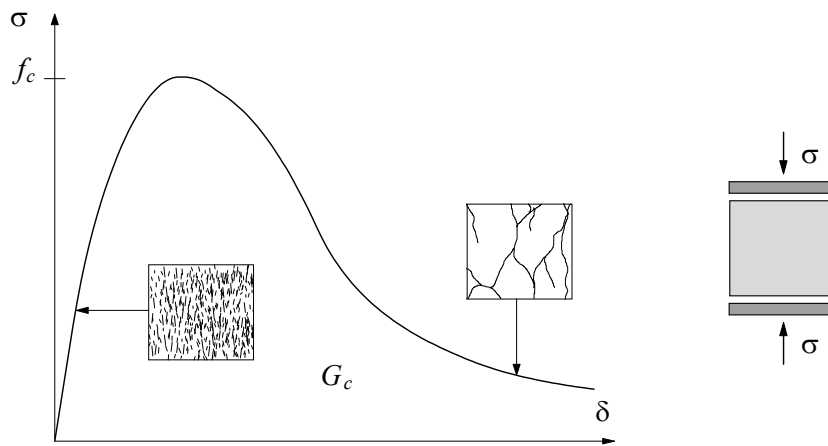

Figure 11 - Typical behaviour of quasi-brittle materials under uniaxial compression and definition of fracture energy (f_c denotes the compressive strength).

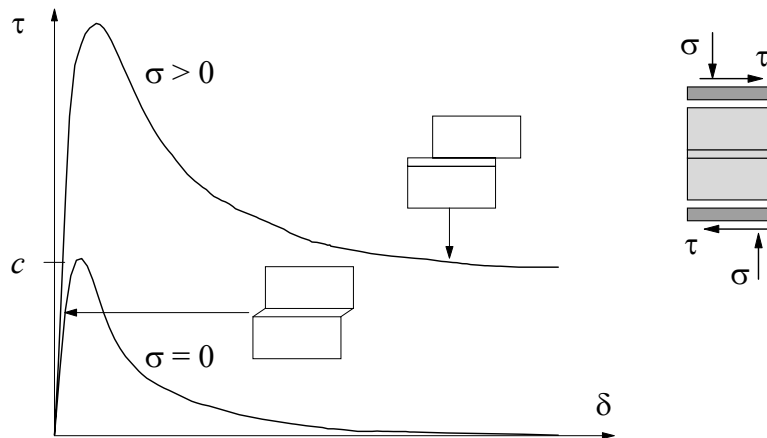

Figure 12 - Behaviour of masonry under shear and definition of mode II fracture energy G_f^{II} (c denotes the cohesion).

2.3 Properties of unit and mortar

The properties of masonry are strongly dependent upon the properties of its constituents. Compressive strength tests are easy to perform and give a good indication of the general quality of the materials used. Eurocode 6 [15] uses the compressive strength of the components to determine the strength of masonry even if a true indication of those values is not simple.

For masonry units, standard tests with solid platens result in an artificial compressive strength due to the restraint effect of the platens. Eurocode 6 [15] minimises this effect by considering a normalised compressive strength f_b , which results from the standard compressive strength, in the relevant direction of loading, multiplied by an appropriate shape/size factor. The normalised compressive strength refers to a cubic specimen with $100 \times 100 \times 100 \text{ mm}^3$ and cannot be considered representative of the true strength. Experiments in the uniaxial post-peak behaviour of

compressed bricks and blocks are virtually non-existent and no recommendations about the compressive fracture energy G_c can be made.

It is difficult to relate the tensile strength of the masonry unit to its compressive strength due to the different shapes, materials, manufacture processes and volume of perforations. For the longitudinal tensile strength of clay, calcium-silicate and concrete units, Schubert [16] carried out an extensive testing program and obtained a ratio between the tensile and compressive strength that ranges from 0.03 to 0.10. For the fracture energy G_f of solid clay and calcium-silicate units, both in the longitudinal and normal directions, van der Pluijm [17] found values ranging from 0.06 to 0.13 Nmm/mm^2 , for tensile strength values ranging from 1.5 to 3.5 N/mm^2 .

Experiments on the biaxial behaviour of bricks and blocks are also lacking in the literature. This aspect gains relevance due to the usual orthotropy of the units due to perforations. As a consequence, the biaxial behaviour of a brick or block with a given shape is likely to be unknown, even if the behaviour of the material from which the unit is made, e.g. concrete or clay, is known.

For the mortar, the compressive strength f_{mo} is obtained from standard tests carried out in the two halves of the $40 \times 40 \times 160 \text{ mm}^3$ prisms used for the flexural test. The specimens are casted in steel moulds and the water absorption effect of the unit is ignored, being thus non-representative of the mortar inside the composite. Currently, investigations in mortar disks extracted from the masonry joints are being carried out to fully characterise the mortar behaviour [18-20]. Nevertheless, there is still a lack of knowledge about the complete mortar uniaxial behaviour, both in compression and tension.

2.4 Properties of the unit-mortar interface

The bond between the unit and mortar is often the weakest link in masonry assemblages. The non-linear response of the joints, which is then controlled by the unit-mortar interface, is one of the most relevant features of masonry behaviour. Two different phenomena occur in the unit-mortar interface, one associated with tensile failure (mode I) and the other associated with shear failure (mode II).

a) Mode I failure (tension)

Different test set-ups have been used for the characterisation of the tensile behaviour of the unit-mortar interface. These include (three-point, four-point, bond-wrench) flexural testing, e.g. [21,22], diametral compression (splitting test), e.g. [23,24] and direct tension testing [25], see Figure 13. For the purpose of numerical simulation, direct tension tests is the one to be adopted as it allows for the complete representation of the stress-displacement diagram and yield the correct strength value. The strength results from other tests must be adjusted by a correction factor.

Van der Pluijm [25] carried out displacement controlled tests in small masonry specimens of solid clay and calcium-silicate units, see Figure 14. These tests resulted in an exponential tension softening curve with a mode I fracture energy G_F^I ranging from 0.005 to 0.02 Nmm/mm^2 , for a tensile bond strength ranging from 0.3 to 0.9 N/mm^2 , according to the unit-mortar combination. This fracture energy is defined as the amount of energy to create a unitary area of a crack along the unit-mortar interface. A close

observation of the cracked specimens revealed that the bond area was smaller than the cross sectional area of the specimen, see Figure 15. This so-called net bond surface seems to concentrate in the inner part of the specimen, which can be a combined result from shrinkage of the mortar and the process of laying units in the mortar bed. For a wall the net bond surface must be corrected according to a smaller number of edges, see Figure 15. The values given above refer to the real cross section of a wall and result from an extrapolation of the measured net bond surface of the specimen to the assumed net bond surface of the wall, neglecting any influence of the vertical joints.

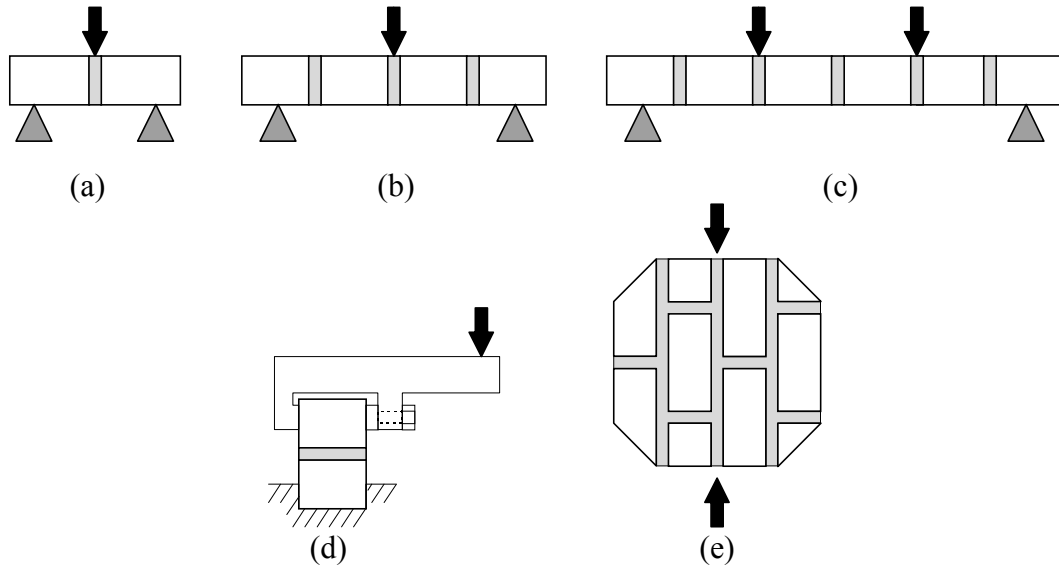

Figure 13 - Possible test set-ups for tensile strength: (a) three-point bending with a single joint; (b) three-point bending with a longer specimen; (c) four-point bending; (d) bond-wrench test; (e) splitting test.

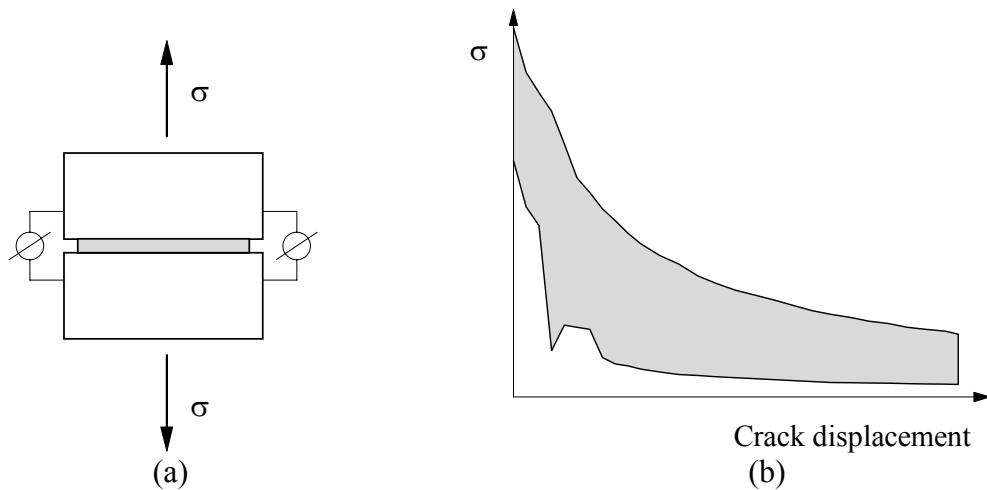

Figure 14 - Tensile bond behaviour of masonry [25]: (a) test specimen (direct tension); (b) typical experimental stress-crack displacement results for solid clay brick masonry (the shaded area represents the envelope of four tests).

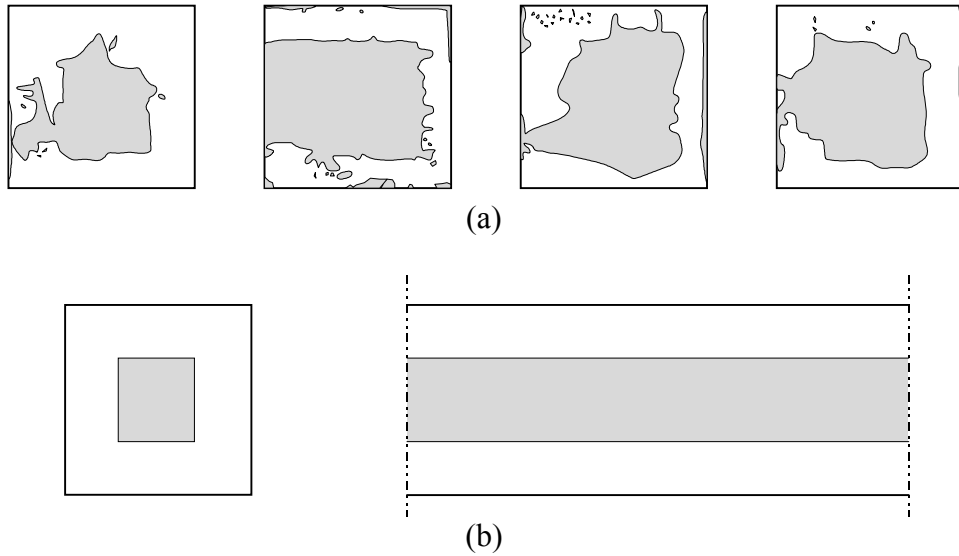

Figure 15 - Tensile bond surface [25]: (a) typical net bond surface for tensile specimens of solid clay units; (b) extrapolation of net bond surface from specimen (35%) to wall (59%).

b) Mode II failure (Shear)

An important aspect in the determination of the shear response of masonry joints is the ability of the test set-up to generate a uniform state of stress in the joints. This objective is difficult because the equilibrium constraints introduce non-uniform normal stresses in the joint. A discussion about the adequacy of different test configurations will not be given here and the reader is referred to [26,27] for this purpose. Different test set-ups have been used for the characterisation of the shear behaviour of the unit-mortar interface. These include direct shear or couplet testing, e.g. [28,29] and triplet tests, e.g. [30,31], see Figure 16. To obtain post-peak characteristics, a key issue during testing is to keep constant the stress normal to the bed joint.

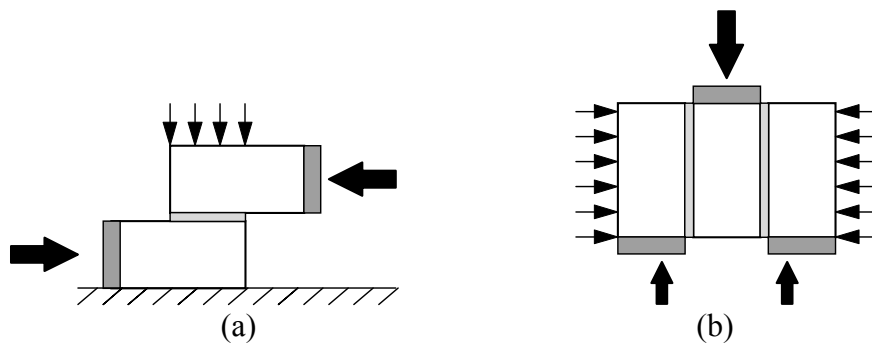

Figure 16 - Possible test set-ups for shear strength: (a) couple test; (b) triplet test.

Van der Pluijm [32] presents the most complete characterisation of the masonry shear behaviour, for solid clay and calcium-silicate units. The test set-up shown in Figure 17 permits to keep a constant normal confining pressure upon shearing. Confining (compressive) stresses were applied with three different levels: 0.1, 0.5 and

1.0 N/mm^2 . The test apparatus did not allow for application of tensile stresses and even for low confining stresses extremely brittle results are found with potential instability of the test set-up. Noteworthy, for several specimens with higher confining stresses shearing of the unit-mortar interface was accompanied by diagonal cracking in the unit.

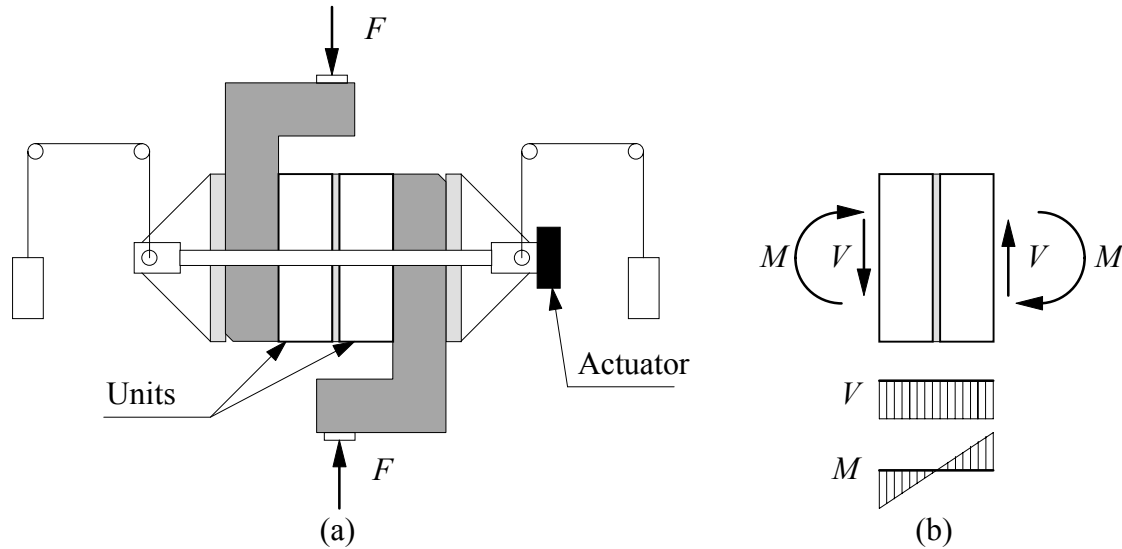

Figure 17 - Test set-up to obtain shear bond behaviour [32]: (a) test specimen ready for testing; (b) forces applied to the test specimen during testing.

The experimental results yield an exponential shear softening diagram with a residual dry friction level, see Figure 18a. The area defined by the stress-displacement diagram and the residual dry friction shear level is named mode II fracture energy G_f^{II} , with values ranging from 0.01 to 0.25 Nmm/mm^2 for initial cohesion c values ranging from 0.1 to 1.8 N/mm^2 . The value for the fracture energy depends also on the level of the confining stress, see Figure 18b. Evaluation of the net bond surface of the specimens is no longer possible but the values measured for tensile bond strength can be assumed to hold. Additional material parameters can be obtained from such an experiment, see Figure 19a. The initial internal friction angle ϕ_0 , associated with a Coulomb friction model, is measured by $\tan\phi_0$, which ranges from 0.7 to 1.2 , for different unit-mortar combinations. The residual internal friction angle ϕ_r is measured by $\tan\phi_r$, which seems to be approximately constant and to equal 0.75 . The dilatancy angle ψ measures the uplift of one unit over the other upon shearing, see Figure 19b. Note that the dilatancy angle depends on the level of the confining stress, see Figure 20a. For low confining pressures, the average value of $\tan\psi$ falls in the range from 0.2 to 0.7 , depending on the roughness of the unit surface. For high confining pressures, $\tan\psi$ decreases to zero. With increasing slip, $\tan\psi$ also decreases to zero due to the smoothing of the sheared surfaces, see Figure 20b.

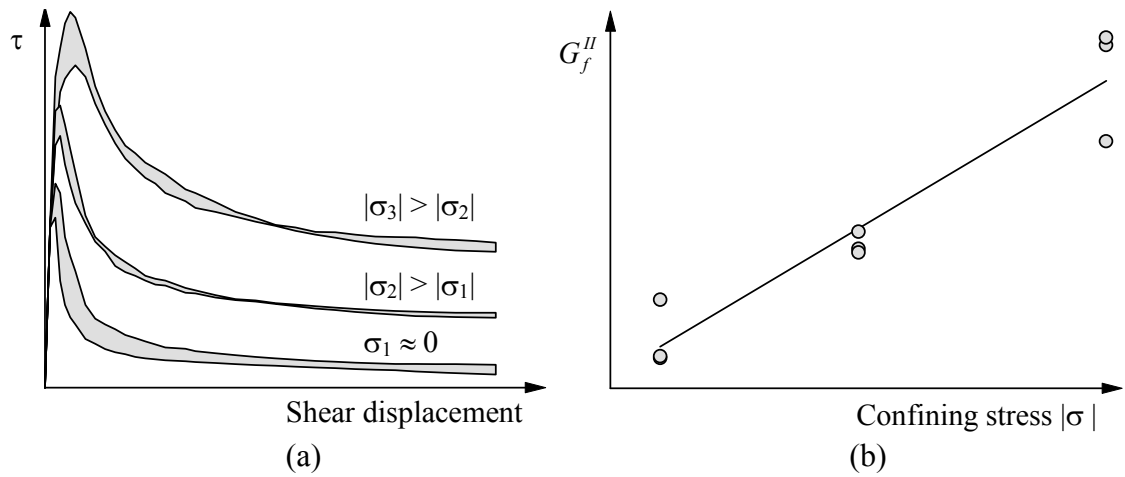

Figure 18 - Typical shear bond behaviour of the joints for solid clay units [32]: (a) stress-displacement diagram for different normal stress levels (the shaded area represents the envelope of three tests); (b) mode II fracture energy G_f^{II} as a function of the normal stress level.

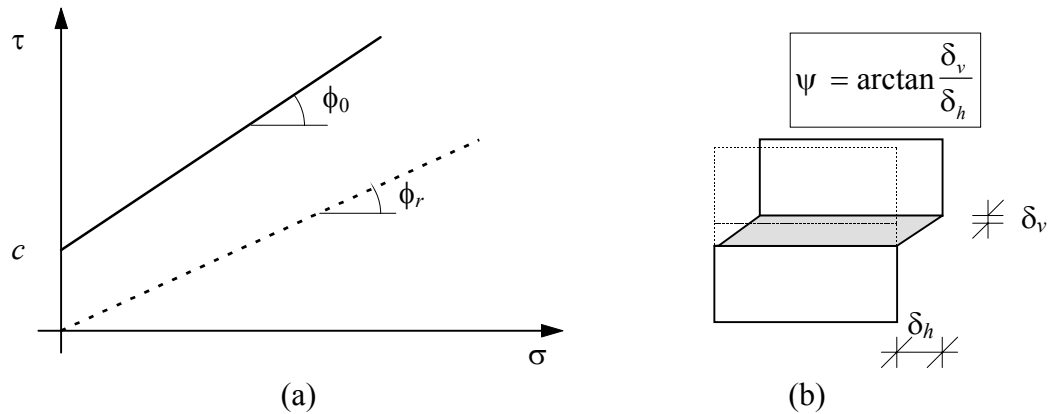

Figure 19 - Definition of friction and dilatancy angles: (a) Coulomb friction law, with initial and residual friction angle; (b) dilatancy angle as the uplift of neighbouring units upon shearing.

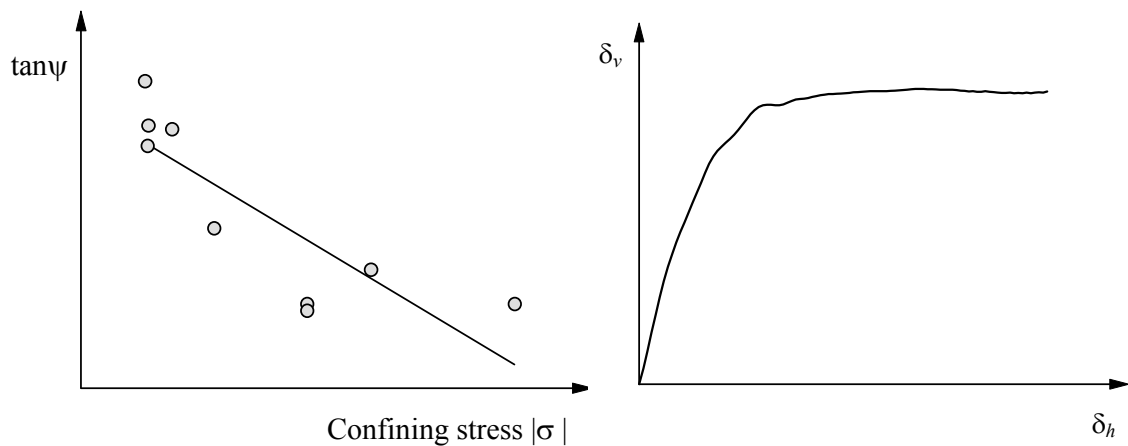

Figure 20 - Typical shear bond behaviour of the joints for solid clay units [32]: (a) tangent of the dilatancy angle ψ as a function of the normal stress level; (b) relation between the normal and the shear displacement upon loading.

2.5 Properties of the composite material

The uniaxial behaviour of the composite material is described next with regard to the material axes, namely the directions parallel and normal to the bed joints.

a) Uniaxial compressive behaviour of masonry

The compressive strength of masonry in the direction normal to the bed joints has been traditionally regarded as the sole relevant structural material property, at least until the recent introduction of numerical methods for masonry structures. A test frequently used to obtain this uniaxial compressive strength is the stacked bond prism, see Figure 21a, but it is still somewhat unclear what are the consequences in the masonry strength of using this type of specimens [33]. It is commonly accepted that the real uniaxial compressive strength of masonry in the direction normal to the bed joints can be obtained from the so-called RILEM test [34], shown in Figure 21b. The RILEM specimen is however relatively large and costly to execute, especially when compared to the standard cube or cylinder tests for concrete.

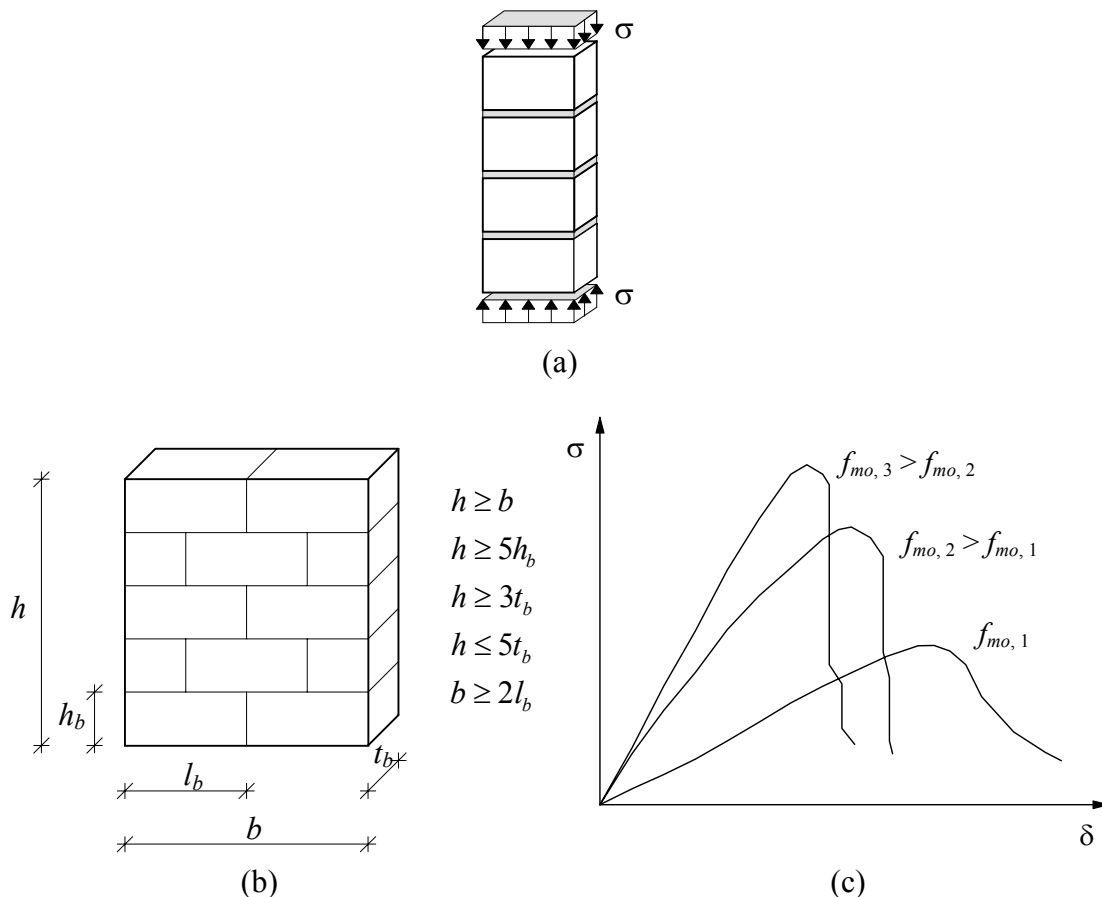

Figure 21 - Uniaxial behaviour of masonry upon loading normal to the bed joints: (a) stacked bond prism; (b) schematic representation of RILEM test specimen; (c) typical experimental stress-displacement diagrams for $500 \times 250 \times 600 \text{ mm}^3$ prisms of solid soft mud brick [35]. Here, f_{mo} is the mortar compressive strength.

Since the pioneering work of Hilsdorf [36] it has been accepted by the masonry community that the difference in elastic properties of the unit and mortar is the precursor of failure. Uniaxial compression of masonry leads to a state of triaxial compression in the mortar and of compression/biaxial tension in the unit. Mann and Betzler [33] observed that, initially, vertical cracks appear in the units along the middle line of the specimen, i.e. continuing a vertical joint. Upon increasing deformation additional cracks appear, normally vertical cracks at the small side of the specimen, that lead to failure by splitting of the prism. Examples of load-displacement diagrams obtained in $500 \times 250 \times 600 \text{ mm}^3$ prisms of solid soft mud bricks are shown in Figure 21c. Increasing strength leads to a more brittle behaviour. The quite high value of the compressive fracture energy G_c , which equals $\approx 45 \text{ Nmm/mm}^2$, can be explained by the continuum fracture energy and the 600 mm height of the specimen [14]. Atkinson and Yan [37] collected information about the compressive stress-strain relation for masonry, but these results are not energy based.

Uniaxial compression tests in the direction parallel to the bed joints have received substantially less attention from the masonry community. However, regular masonry is an anisotropic material and, particularly in the case of low longitudinal compressive strength of the units due to high or unfavourable perforation, the resistance to compressive loads parallel to the bed joints can have a decisive effect on the load bearing capacity. According to [38], the ratio between the uniaxial compressive strength parallel and normal to the bed joints ranges from 0.2 to 0.8.

It is noted that displacement controlled results for masonry in compression are practically non-existent. This can be understood by the fact that most inelastic phenomena in masonry are due to tension and shear. Nevertheless, for confined masonry and historical constructions, crushing of masonry can be of relevance and more research is clearly needed in this area.

b) Uniaxial tensile behaviour of masonry

For tensile loading perpendicular to the bed joints, failure is generally caused by failure of the relatively low tensile bond strength between the bed joint and the unit. As a rough approximation, the masonry tensile strength can be equated to the tensile bond strength between the joint and the unit.

In masonry with low strength units and greater tensile bond strength between the bed joint and the unit, e.g. high-strength mortar and units with numerous small perforations, which produce a dowel effect, failure may occur as a result of stresses exceeding the unit tensile strength. As a rough approximation, the masonry tensile strength in this case can be equated to the tensile strength of the unit.

For tensile loading parallel to the bed joints tests similar to the ones shown in Figure 13 are possible but they suffer from the drawbacks pointed earlier and do not allow for a complete characterisation of the stress-displacement diagram. An adequate direct tension test program was set-up by Backes [39], in which the specimen consists of four courses, initially laid down in the usual manner, see Figure 22a. A special device attached to the specimen turns it 90° in the intended direction of testing shortly before the test time, see Figure 22b. The load is applied via steel plates attached to the top and bottom of the specimen by a special glue. The entire load-displacement diagram is traced upon displacement control.

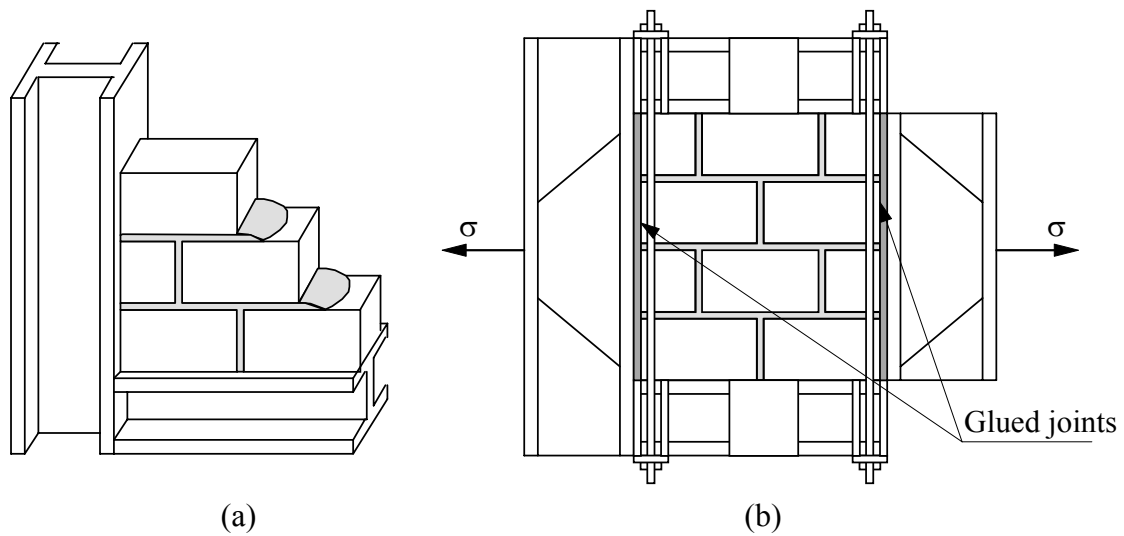

Figure 22 - Test set-up for tensile strength of masonry parallel to the bed joints [39]: (a) building of the test specimen; (b) test specimen before 90° rotation and testing.

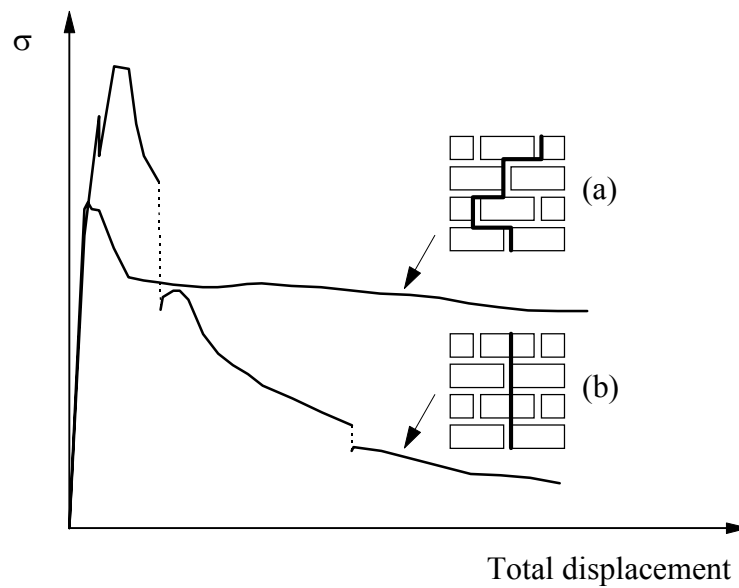

Figure 23 - Typical experimental stress-displacement diagrams for tension in the direction parallel to the bed joints [39]: (a) failure occurs with a stepped crack through head and bed joints; (b) failure occurs vertically through head joints and units.

Two different types of failure are possible, depending on the relative strength of joints and units, see Figure 23 and Figure 24. In the first type of failure, cracks zigzag through head and bed joints. A typical stress-displacement diagram shows some residual plateau upon increasing deformation. The post-peak response of the specimen is governed by the fracture energy of the head joints and the post-peak mode II behaviour of bed joints, i.e. tension of the head joints and shearing of the bed joints. In the second type of failure, cracks run almost vertically through the units and head joints.

A typical stress-displacement diagram shows progressive softening until zero. The post-peak response is governed by the fracture energy of the units and head joints.

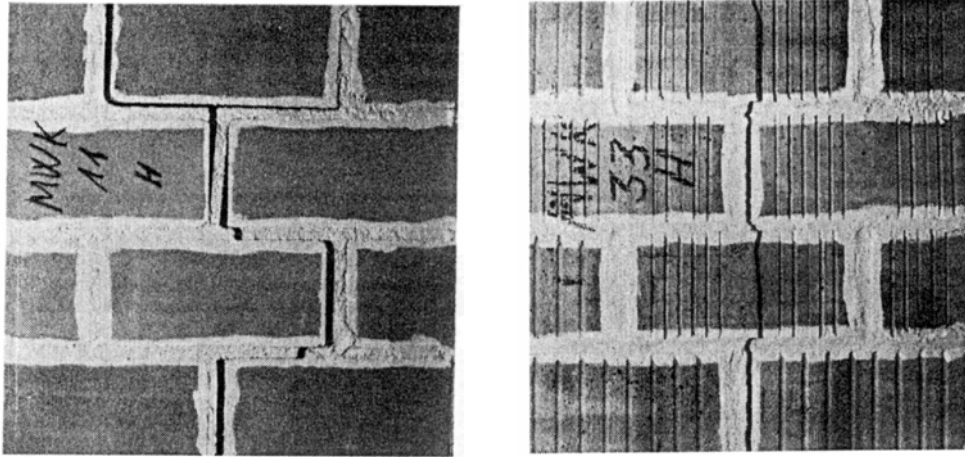

Figure 24 - Typical failure patterns of the specimens [39].

c) Biaxial behaviour

The constitutive behaviour of masonry under biaxial states of stress cannot be completely described from the constitutive behaviour under uniaxial loading conditions. The influence of the biaxial stress state has been investigated up to peak stress to provide a biaxial strength envelope, which cannot be described solely in terms of principal stresses because masonry is an anisotropic material. Therefore, the biaxial strength envelope of masonry must be either described in terms of the full stress vector in a fixed set of material axes or, in terms of principal stresses and the rotation angle θ between the principal stresses and the material axes. Basically, two different test set-ups have been utilised, uniaxial compression oriented at a given angle with respect to the bed joints, e.g. [40,41] and true biaxial loading at a given angle with respect to the bed joints, e.g. [42-44], see Figure 25.

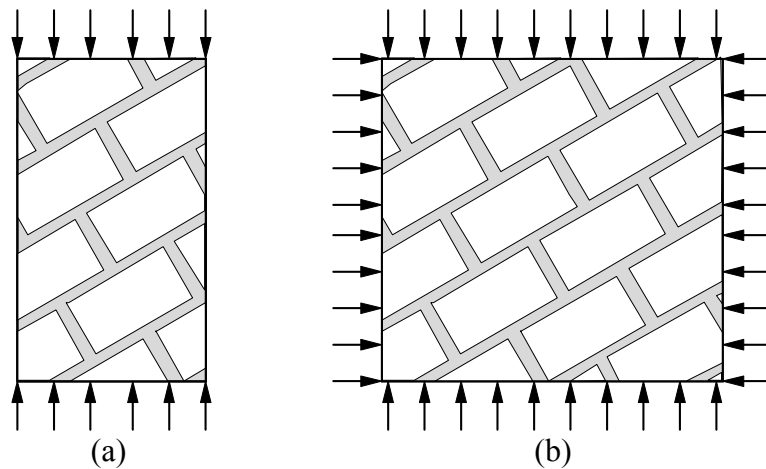

Figure 25 - Possible test set-ups for biaxial strength: (a) uniaxial loading; (b) biaxial loading.

The most complete set of experimental data of masonry subjected to proportional biaxial loading has been carried out by Page [42,43] and it is shown in Figure 26. The tests were carried out with half scale solid clay units and the load was applied with steel brush platens. Both the orientation of the principal stresses with regard to the material axes and the principal stress ratio considerably influence the failure mode and strength. The different modes of failure are illustrated in Figure 27.

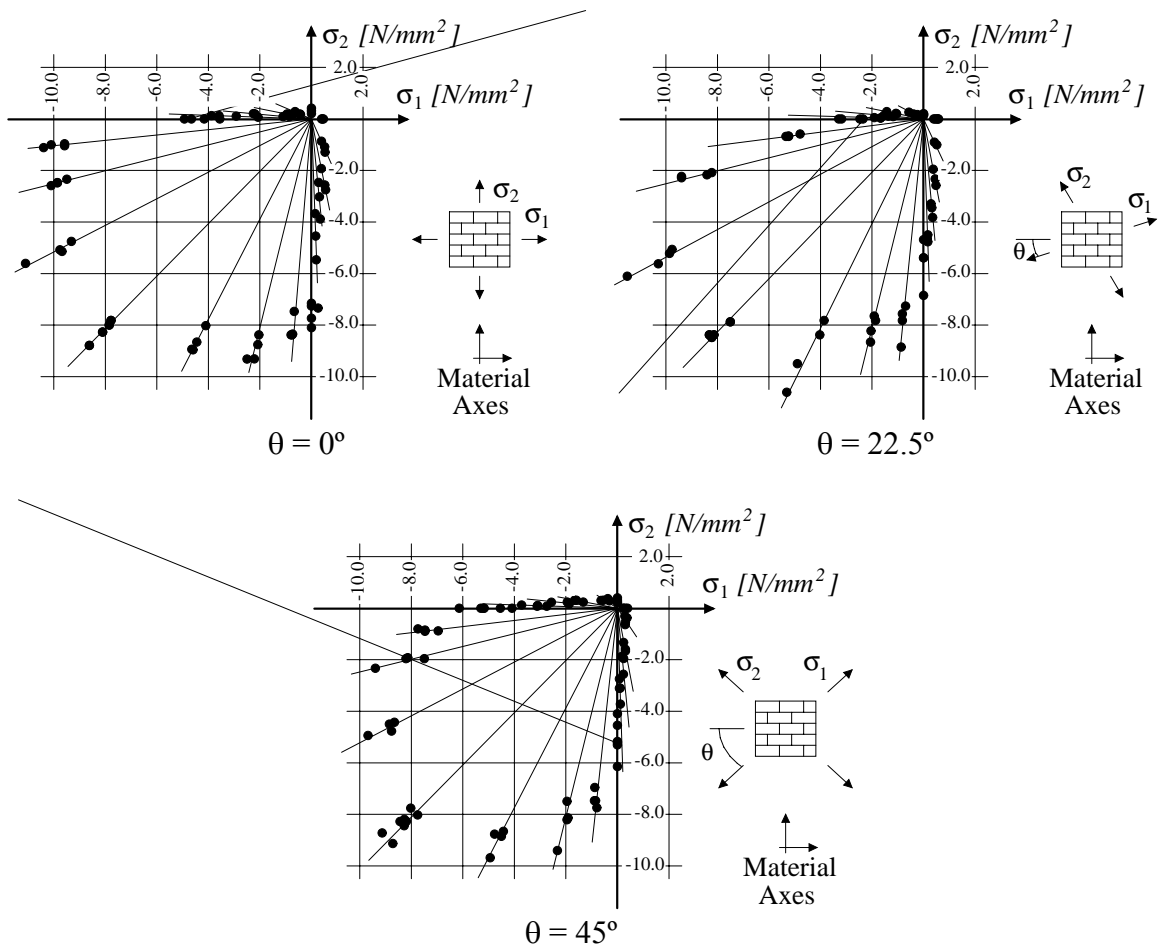

Figure 26 - Biaxial strength of solid clay units masonry [42,43].

For uniaxial tension, failure occurred by cracking and sliding of the head and bed joints. The influence of the lateral tensile stress in the tensile strength is not known because no experimental results are available. A lateral compressive stress decreases the tensile strength, which can be explained by the damage induced in the composite material, by micro-slip of the joints and micro-cracking of the units. In the tension-compression loading cases failure occurred either by cracking and sliding of the joints alone or in a combined mechanism involving both units and joints. Similar types of failure occurred for uniaxial compression but a smooth transition is found to other type of failure mode in biaxial compression. In biaxial compression failure typically occurred by splitting of the specimen at mid-thickness, in a plane parallel to its free surface, regardless of the orientation of the principal stresses. For principal stress ratios

$\ll 1$ and $\gg 1$, the orientation played a significant role and failure occurred in a combined mechanism involving both joint failure and lateral splitting. The increase of compressive strength under biaxial compression can be explained by friction in the joints and internal friction in the units and mortar.

It is noted that experimental data about the softening of masonry under biaxial loading are very scarce, particularly for deformation characteristics. Tracing complete stress-displacement diagrams is fundamental for the purpose of numerical simulations, even if this challenge reveals some difficulties with most experimental set-ups.

It is further noted that the strength envelope shown in Figure 26 is of limited applicability for other types of masonry. Different strength envelopes and different failure modes are likely to be found for different materials, unit shapes and geometry. A comprehensive program to characterise the biaxial strength of different masonry types has been carried out in Switzerland using full scale specimens, see [44] for hollow clay units masonry, [46] for clay and calcium-silicate units masonry and [47] for concrete units masonry.

Angle θ	Uniaxial tension	Tension/compression	Uniaxial compression	Biaxial compression
0°				
22.5°				
45°				
67.5°				
90°				

Figure 27 - Modes of failure of solid clay units masonry under biaxial loading [45].

3. RECENTLY DEVELOPED NUMERICAL MODELS

A detailed analysis of masonry must include the representation of units and the mortar joints. This kind of analysis is particularly adequate for small structures, subjected to states of stress and strain strongly heterogeneous, and demands the knowledge of each of the constituents of masonry (unit and mortar) as well as the interface. In terms of modelling, all the non-linear behaviour can be concentrated in the interface elements for the joints and for straight potential vertical cracks in the centre line of all units. A complete micro-model must include all the failure mechanisms of masonry, namely, cracking of joints, sliding over one head or bed joint, cracking of the units and crushing of masonry. Page [48] performed the first attempt to use a micro-model for masonry structures, using interface elements. Non-linear behaviour was incorporated in a primitive way, with fragile behaviour in tension and hardening in shear/compression. The adopted constitutive laws are in opposition with recent experimental results, e.g. [25,26,32]. In fact, the models presented by most authors, using either finite elements, e.g. [49-52], or discrete elements, e.g. [53,54], do not represent significant improvements with respect to the original model of [48]. In general, these models fail to consider all the failure mechanisms of masonry and adopt primitive constitutive laws. A model that includes all possible failure mechanisms of masonry was recently developed [55], see Figure 28, and allows for the input of the correct material properties obtained in advanced laboratory tests. The sophisticated tests described earlier, performed under displacement control, are able to characterise the post-peak behaviour of the materials. The behaviour of the model is illustrated in Figure 29. This model includes inelastic behaviour in tension (cracking), in shear (sliding) and in compression (crushing).

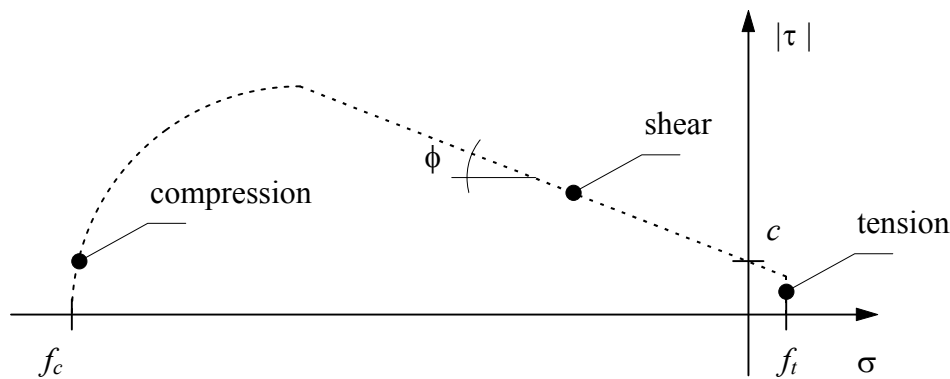

Figure 28 - Interface model for masonry (plane stress representation) [55].

Figure 30 shows the results of modelling a shear wall with an initial vertical pre-compression pressure. The horizontal force F drives the wall to failure, keeping the top and bottom boundaries fully constrained, and produces a horizontal displacement d at top. Initially, two horizontal cracks develop at the top and bottom of the wall but, at failure, a diagonal stepped crack and crushing of the compressed toes are found. A complete discussion of the numerical results has been given in [55].

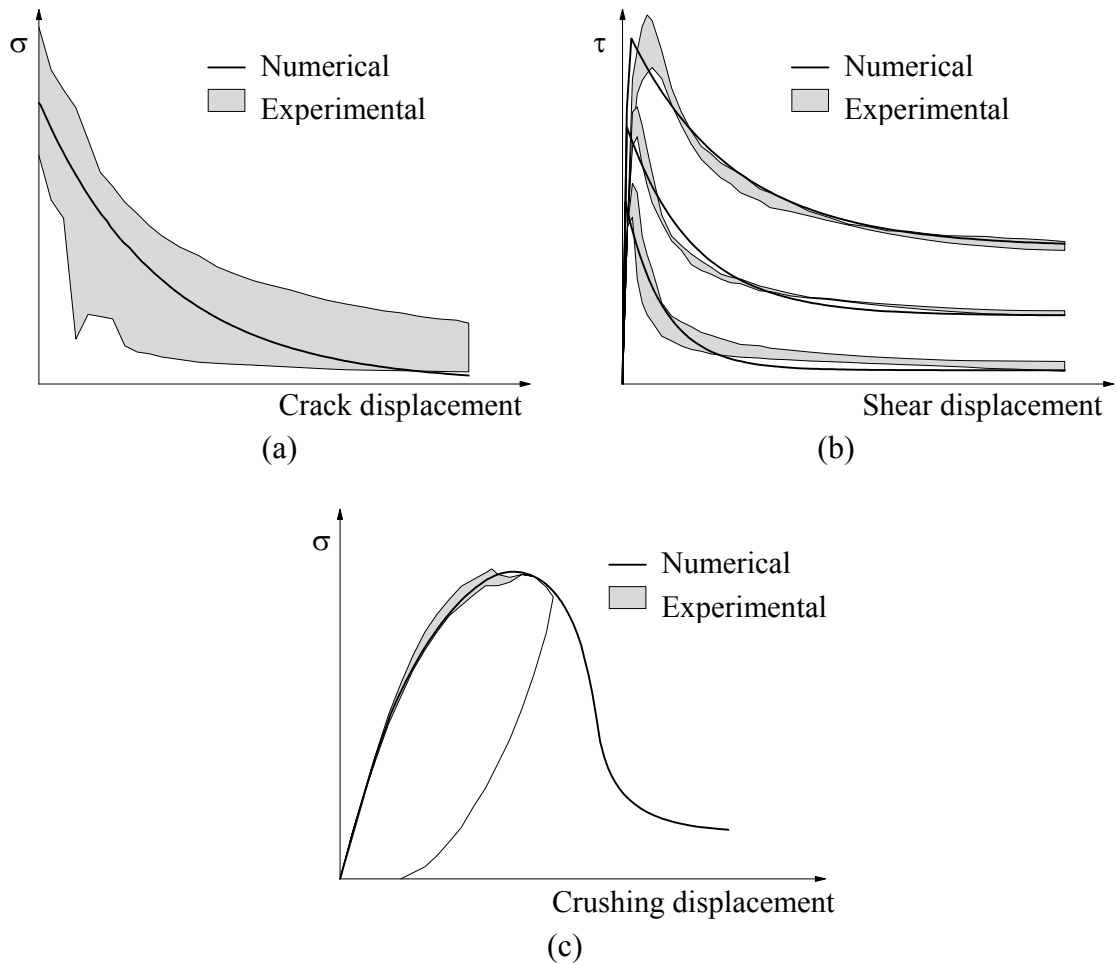

Figure 29 - Behaviour of the model for (a) uniaxial tension, (b) shear and (c) uniaxial compression.

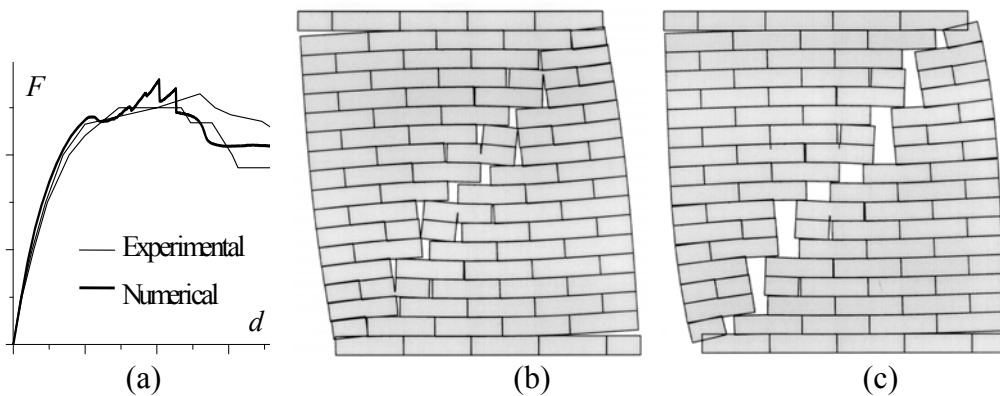

Figure 30 - Results for a shear wall: (a) force-displacement diagram; (b,c) deformed meshes at peak and ultimate load.

Figure 31 shows the results of modelling a pier-wall connection subjected to wind load. Initially, a uniformly distributed vertical load is applied, before a horizontal load at the top of the wall drives it to failure. A detailed comparison between experimental and numerical results can be found in [8]. In a first phase, the piers and

wall are firmly glued, which yields a very stiff structure. At a certain stage, around peak load, separation between the two piers and the wall occurs. After this stage, a much lower load can be carried by the structure because piers and wall behave independently and slide over each other.

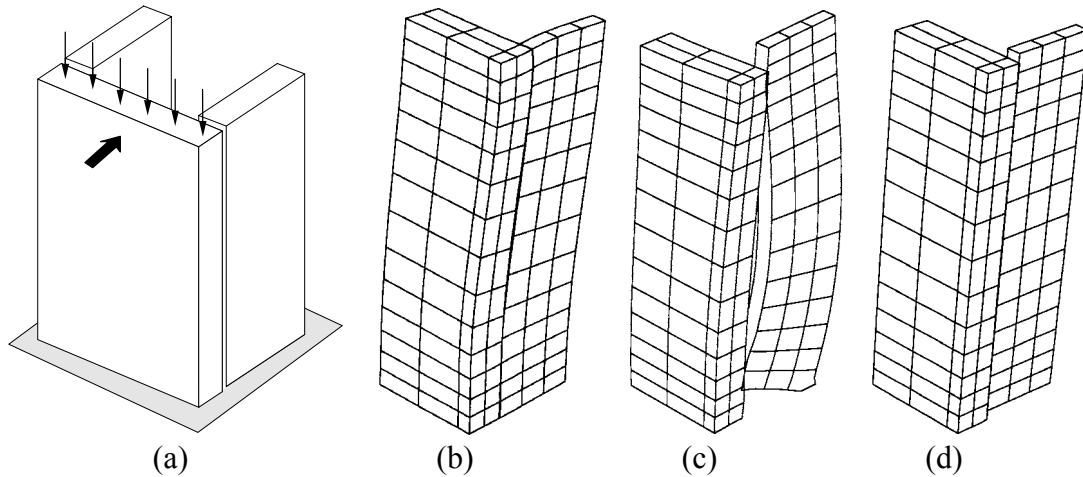

Figure 31 - Results for a pier-wall connection: (a) geometry and load; (b,c,d) incremental deformed meshes (only $\frac{1}{2}$ of the wall is shown) before, during and after separation.

Figure 32 shows results of a pier subjected to a point load. In the centre of the pier a splitting crack arises which propagates in a catastrophic manner after peak load. The computed crack path is straight and vertical indicating that the crack jumps from head joint to head joint right through the unit.

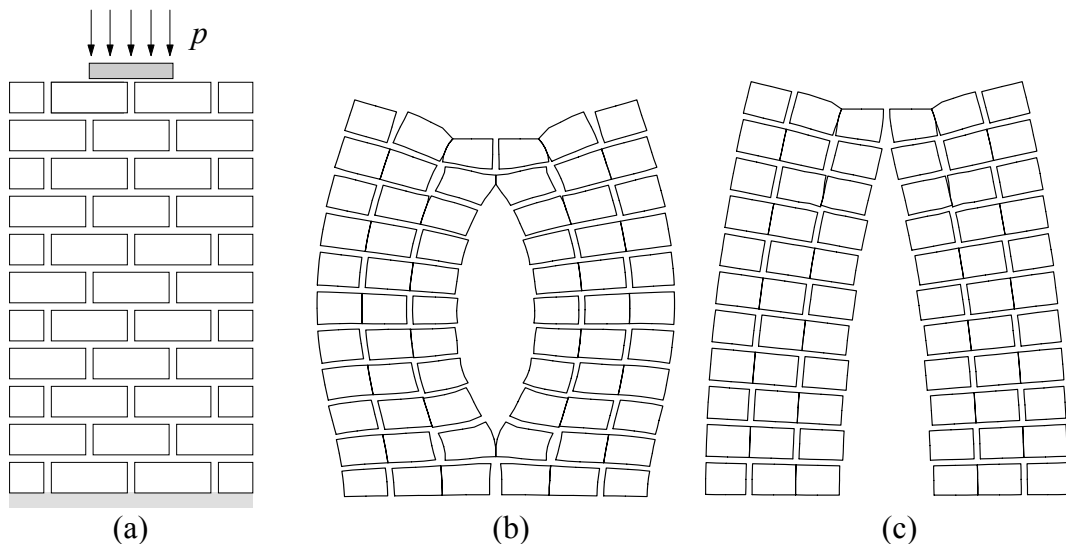

Figure 32 - Results for a pier subjected to a point load: (a) geometry and load; (b,c) incremental deformed meshes at peak and ultimate load.

The examples above demonstrate the power of modern numerical tools to represent the complex interaction between masonry components (units and joints). The

response of plane and three-dimensional structures controlled by the local behaviour of masonry and difficult phenomena observed in the experiments can be reproduced.

In large structures, the knowledge of the behaviour of the interaction between units and joints does not usually determine the global behaviour of the structure. In this case, it more adequate to resort to continuum models, which establish the relation between average stresses and averages strains in masonry. Difficulties of conceiving and implementing macro-models for the analysis of masonry structures arise especially due to the fact that almost no comprehensive experimental results are available (either for pre- and post-peak behaviour), but also due to the intrinsic complexity of formulating anisotropic inelastic behaviour. Only a reduced number of authors tried to develop specific models for the analysis of masonry structures [45,56]. Nevertheless, none of the cited authors included rationally softening in tension and compression. Moreover, the above models are incapable of handling the prediction of structural behaviour after peak load, being, therefore, incapable of establishing the safety of the structure. Additionally, the proposed yield surfaces are rather complex which almost preclude the use of modern plasticity concepts and an accurate representation of inelastic behaviour (hardening and softening).

Formulations of isotropic quasi-brittle materials behaviour consider, generally, different inelastic criteria for tension and compression. The new model introduced in [57] combines the advantages of modern plasticity concepts with a powerful representation of anisotropic material behaviour, which includes different hardening/softening behaviour along each material axis. The model includes the combination of a Rankine-like yield surface for tension and a Hill-like yield surface in compression, see Figure 33. The behaviour of the model in uniaxial tension and uniaxial compression, along two orthogonal directions is given in Figure 34. This composite surface permits to reproduce the results obtained in uniaxial tests, in which different behaviour are obtained along different directions. The application of the model in structural modelling of masonry structures lead to excellent results, both in terms of collapse loads and in terms of reproduced behaviour, see [58].

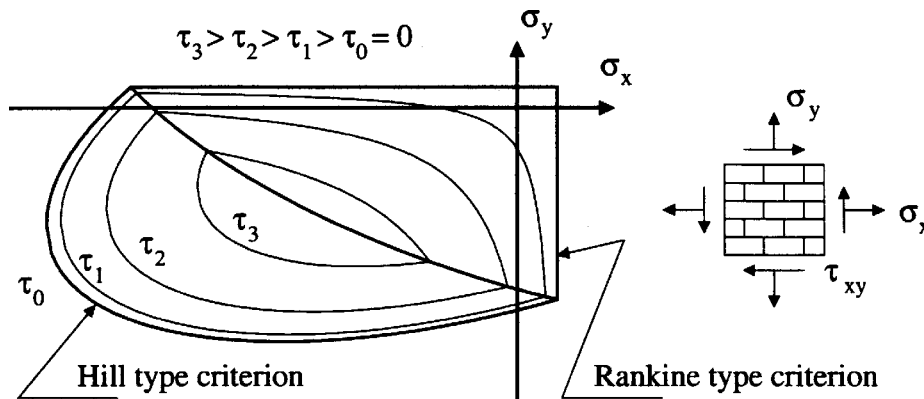

Figure 33 - Continuum failure surface for masonry (plane stress representation) [57].

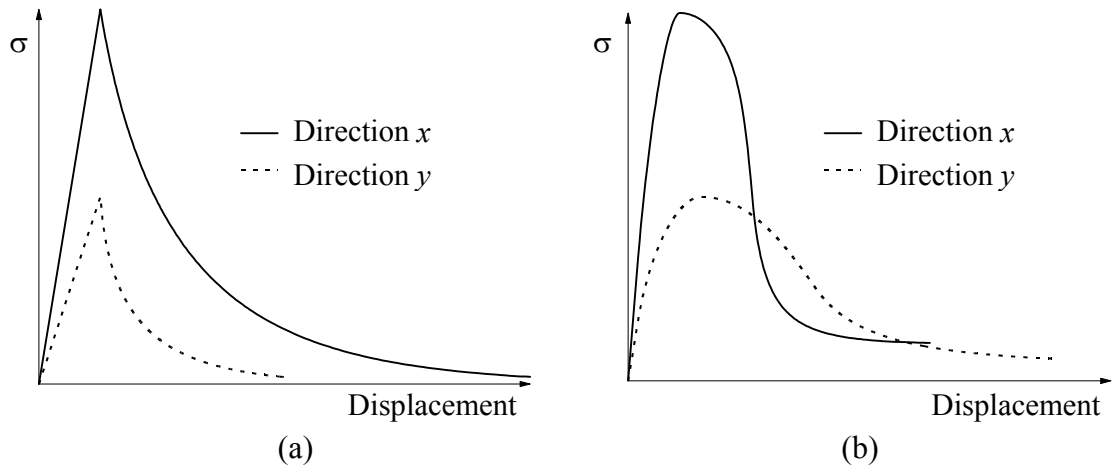

Figure 34 - Behaviour of the model for (a) tension and (b) compression, along two orthogonal directions.

Figure 35 shows the results of modelling another shear wall with an initial vertical pre-compression pressure. The horizontal force F drives the wall to failure and produces a horizontal displacement d at top. The wall is confined by two concrete slabs (top and bottom) and two masonry flanges (left and right). This confinement and the large size of the wall make it appropriate for continuum modelling. Initially, cracking occurs well distributed in the panel and finally concentrates in a single shear band from one corner of the panel to the other. The compressive stresses are well below the crushing strength of masonry, i.e. failure is dominated by tension. A complete discussion of the numerical results has been given in [58].

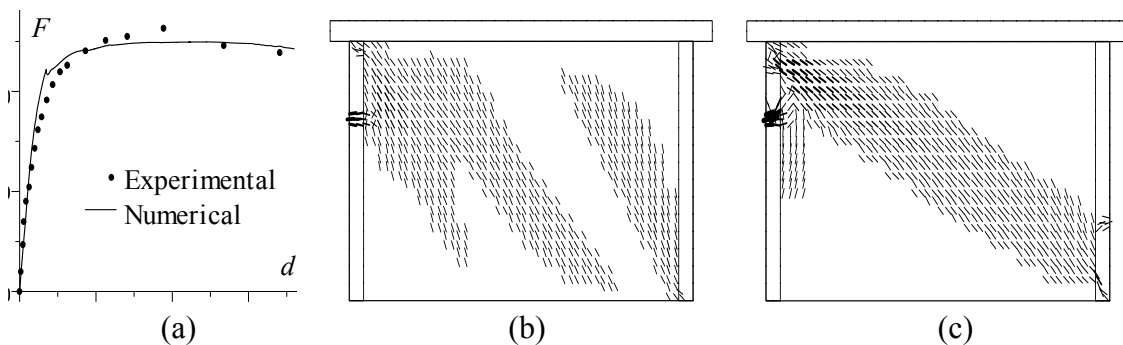

Figure 35 - Results for masonry shear wall: (a) load-displacement diagram; (b,c) predicted cracking pattern at peak and ultimate load.

Figure 36 shows the results of modelling a panel with out-of-plane pressure. The panel is simply supported on two sides (left and right), fully clamped on one side (bottom) and free on the other (top). The central opening simulates a window and the panel was loaded with an air-bag with a uniformly distributed load. The predicted form of collapse includes diagonal cracks from each lower corner of the panel up to the opening, which were also observed in the experiments. This form of yield line collapse

does not mean that yield line design is safe due to the quasi-brittle behaviour of the material. A complete discussion of the numerical results has been given in [59].

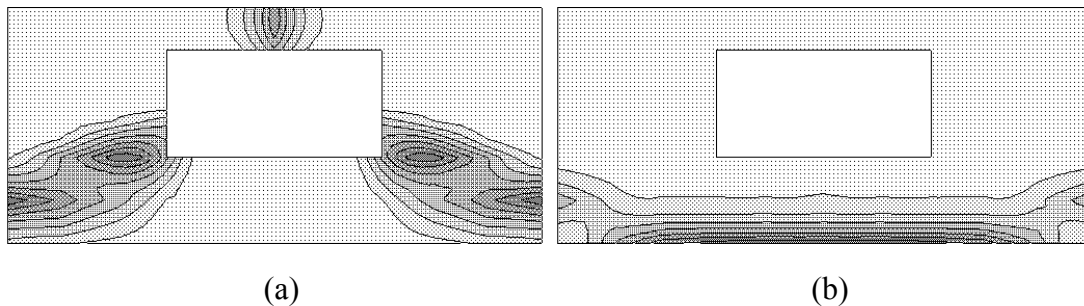

Figure 36 - Results for a panel subjected to uniform out-of-plane loading: predicted cracking pattern at (a) bottom and (b) top face of the panel.

Finally, Figure 37 shows the results of a study concerning an investigation of the expected damage in old masonry buildings due to tunnelling. A block of ten façades supported on wooden piles is adopted for this purpose. The applied loads include the self-weight of the structure, dead and live floor loads and the settlements of the piles induced by boring a tunnel parallel to the façade, from right to left. The settlements occur gradually with the construction of the tunnel, starting from the right end of the building. Once the loading process is completed a uniform settlement which amounts to 12.9 mm is obtained. The complete description of the finite element model, including geometry, material properties as well as loading and boundary conditions, is given in [60,61]. Based on results of the analysis both the need for repair techniques or the need to reduce the settlement by a better tunnelling process can be studied. A complete discussion of the behaviour of the structure and criteria for damage acceptance can be found in [60,61].

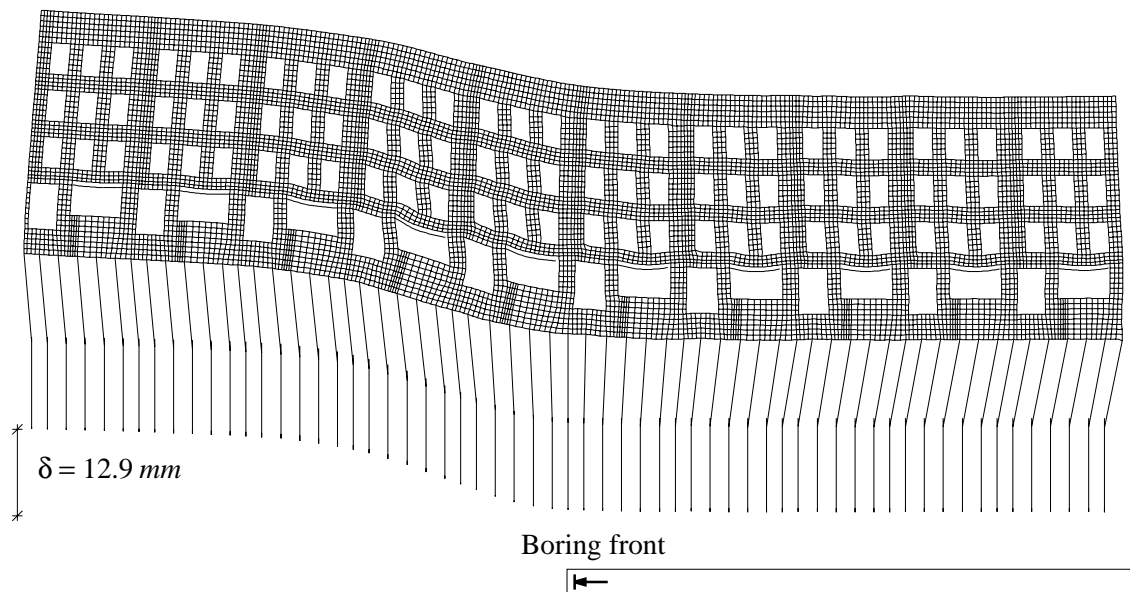

Figure 37 - Results for settlement analysis due to tunnelling: deformed mesh for boring front position at the middle of the structure.

The examples above demonstrate the power of modern numerical tools to represent the composite behaviour of masonry structures. The response of plane and shell masonry structures can be reproduced, provided that they feature well distributed failure mechanisms.

4. CONCLUSIONS

The analysis of historical constructions is a difficult task due to the large numbers of unknown influence factors. Sophisticated techniques of analysis are essential to understand the behaviour of this type of constructions and to control the importance of the different influence factors. Once the appropriate level of confidence and the understanding of the main influence factors in the simulations are achieved, the analysts will be able to adopt the simplifications necessary to make the calculations with the required safety factors.

Masonry is a composite material that consists of units and mortar. The failure mechanism of the material includes tensile failure of units and joints, shear failure of joints and compressive failure of the composite. If a micro-modelling strategy is used all these phenomena can be incorporated in the model because joints and units are represented separately. In a macro-modelling strategy joints are smeared out in an anisotropic homogeneous continuum and the interaction between the components cannot be incorporated in the model. Instead, a relation between average stresses and strains is established.

Independently of the type of strategy adopted, accurate masonry models can only be used if a complete material description is available. This is not generally the case because experimental data suitable for numerical purpose are scarce, especially in the softening regime. An overview of relevant testing apparatus and results has been given. The objective is not only to give insight in the material behaviour, but also to demonstrate that it is possible to fully characterise the material behaviour in the form necessary to accurate non-linear finite element analyses. It requires only closer co-operation between the numerical and experimental scientific community.

REFERENCES

1. MUSGROVE, J. and FLETCHER, B. - "*Sir Banister Fletcher's: A History of Architecture*". Butterworths, London, 1987.
2. DAVEY, N. - "*A History of Building Materials*". Phoenix House, London, 1961.
3. BINDA, L - 'Restoration of heritage masonry buildings', Proc. Seventh Canadian Masonry Symp., Hamilton, Ontario, 23-42, 1995.
4. VITRUVIUS - "*The Ten Books of Architecture*". Dover Publications, New York, 1960.
5. COLDSTREAM, N. - "*Medieval Craftsmen: Masons and Sculptors*". British Museum Press, London, 1990.
6. ELLIOT, C.D. - "*Technics and Architecture: The Development of Materials and Systems for Buildings*". MIT Press, Cambridge, Massachusetts, 1994.
7. MOLLINS, C. - 'Characterisation of the mechanical behaviour of masonry', Structural Analysis of Historical Constructions: Possibilities of Numerical and Experimental Techniques, Ed. P. Roca *et al.*, CIMNE, Barcelona, 86-122, 1997.

8. CUR - “*Structural masonry: a experimental/numerical basis for practical design rules*” (in Dutch). Report 171, CUR, Gouda, 1994.
9. HENDRY, A.W. - “*Structural Masonry*”. MacMillan Education, London, 1990.
10. DRYSDALE, R.G., HAMID, A.A. and BAKER, L.R. - “*Masonry Structures: Behavior and Design*”. Prentice-Hall, Englewood Cliffs, New Jersey 1994.
11. ROTS, J.G. - Numerical simulation of cracking in structural masonry, *Heron*, 36(2), 49-63, 1991.
12. HORDIJK, D.A. - “*Local approach to fatigue of concrete*”. Ph.D. Dissertation, Delft University of Technology, Delft, 1991.
13. MIER, J.G.M. VAN - “*Strain-softening of concrete under multiaxial loading conditions*”. Ph.D. Dissertation, Eindhoven University of Technology, Eindhoven, 1984.
14. VONK, R.A. - “*Softening of concrete loaded in compression*”. Ph.D. Dissertation, Eindhoven University of Technology, Eindhoven, 1992.
15. CEN - “*Eurocode 6: Design of masonry structures*”. ENV 1996-1-1:1995, CEN, Brussels, Belgium, 1995.
16. SCHUBERT, P. - ‘The influence of mortar on the strength of masonry’, Proc. 8th Int. Brick and Block Masonry Conf., Ed. J.W. de Courcy, Elsevier Applied Science, London, 162-174, 1988.
17. PLUIJM, R. VAN DER - ‘Material properties of masonry and its components under tension and shear’, Proc. 6th Canadian Masonry Symp., Ed. V.V. Neis, Saskatoon, Saskatchewan, 675-686, 1992.
18. SCHUBERT, P. and HOFFMANN - ‘Compressive strength of mortar in masonry: Significance, influences, test methods, requirements’, Proc. 10th Int. Brick and Block Masonry Conf., Ed. N.G. Shrive and A. Huizer, Calgary, Alberta, 1335-1344, 1994.
19. STÖCKL, S., BIERWIRTH, H. and KUPFER, H. - ‘The influence of test method on the results of compression tests on mortar’, Proc. 10th Int. Brick and Block Masonry Conf., Ed. N.G. Shrive and A. Huizer, Calgary, Alberta, 1397-1406, 1994.
20. VERMELTFOORT, A. - ‘Mechanical compressive cylinders of small sized mortar cylinders’, Proc. 8th Canadian Masonry Symp., Ed. A.E. Elwi and M.A. Hatzinikolas, Jasper, Alberta, 336-347, 1998.
21. GAZZOLA, E.A., DRYSDALE, R.G. and ESSAWY, A.S. - ‘Bending of concrete masonry walls at different angles to the bed joints’, Proc. 3rd North Amer. Masonry Conf., Arlington, Texas, Paper 27, 1985.
22. SCHUBERT and HETZEMACHER - On the flexural strength of masonry, *Masonry International*, 6(1), 21-28, 1992.
23. JOHNSON, F.B. and THOMPSON, J.N. - ‘Development of diametral testing procedures to provide a measure of strength characteristics of masonry assemblage’, Designing, engineering and constructing with masonry products, Ed. F.H. Johnson, Gulf Publishing Company, Houston, Texas, p. 51-57, 1969.
24. DRYSDALE, R.G., HAMID, A.A. and HEIDEBRECHT, A.C. - Tensile strength of concrete masonry, *J. Struc. Div.*, ASCE, 105(7), 1261-1276, 1979.
25. PLUIJM, R. VAN DER - Non-linear behaviour of masonry under tension, *Heron*, 42(1), 25-54, 1997.
26. ATKINSON, R.H., AMADEI, B.P., SAEB, S. and STURE, S. - Response of masonry bed joints in direct shear, *J. Struc. Engrg.*, ASCE, 115(9), 2276-2296, 1989.

27. JUKES, P. and RIDDINGTON, J.R. - A review of masonry joint shear strength test methods, *Masonry International*, 11(2), 37-41, 1997.
28. SINHA, B.P. and HENDRY A.W. - Further investigations of bond tension, bond shear and the effect of precompression on the shear strength of model brick masonry couplets. B. Ceram. R.A., Tech. Note 80, 1966.
29. HOFMANN, P. and STÖCKL, S. - Tests on the shear-bond behaviour in the bed-joints of masonry, *Masonry International*, 9, 1-15, 1986.
30. SMITH, B.S. and CARTER, C. - Hypothesis for shear failure of brickwork, *J. Struc. Div.*, ASCE, 97(4), 1055-1062, 1977.
31. HENDRY, A.W. - A note on the shear strength of brickwork in combined racking shear and compression, *Proc. Brit. Ceram. Soc.*, 27, 47-52, 1978.
32. PLUIJM, R. VAN DER - 'Shear behavior of bed joints', Proc. 6th North American Masonry Conf., Ed. A.A. Hamid and H.G. Harris, Philadelphia, Pennsylvania, 125-136, 1993.
33. MANN, W. and BETZLER, M. - 'Investigations on the effect of different forms of test samples to test the compressive strength of masonry', Proc. 10th Int. Brick and Block Masonry Conf., Ed. N.G. Shrive and A. Huizer, Calgary, Alberta, 1305-1313, 1994.
34. WESCHE, K. and ILANTZIS, A. - General recommendations for methods of testing load bearing walls, *Materials and Structures*, RILEM, 13(78), 433-445, 1980.
35. BINDA, L., FONTANA, A. and FRIGERIO, G. - 'Mechanical behavior of brick masonries derived from unit and mortar characteristics', Proc. 8th Int. Brick and Block Masonry Conf., Ed. J.W. de Courcy, Elsevier Applied Science, London, 205-216, 1988.
36. HILSDORF, H.K. - 'Investigation into the failure mechanism of brick masonry loaded in axial compression', Designing, engineering and constructing with masonry products, Ed. F.H. Johnson, Gulf Publishing Company, Houston, Texas, 34-41, 1969.
37. ATKINSON, R.H. and YAN, G.G. - Results of a statistical study of masonry deformability, *The Masonry Society Journal*, 9(1), 81-94, 1990.
38. HOFFMANN, G. and SCHUBERT, P. - 'Compressive strength of masonry parallel to the bed joints', Proc. 10th Int. Brick and Block Masonry Conf., Ed. N.G. Shrive and A. Huizer, Calgary, Alberta, 1453-1462, 1994.
39. BACKES, H.-P. - "On the behavior of masonry under tension in the direction of the bed joints" (in German). Ph.D. Dissertation, Aachen University of Technology, Aachen, 1985
40. HAMID, A.A. and DRYSDALE, R.G. - Concrete masonry under combined shear and compression along the mortar joints, *ACI Journal*, 314-320, 1981.
41. SAMARASINGHE, W. and HENDRY, A.W. - The strength of brickwork under biaxial tensile and compressive stress, Proc. 7th Int. Symp. on Load Bearing Brickwork, London, 129-139, 1980.
42. PAGE, A.W. - The biaxial compressive strength of brick masonry, *Proc. Intsn. Civ. Engrs.*, Part 2, 71, 893-906, 1981.
43. PAGE, A.W. - The strength of brick masonry under biaxial compression-tension, *Int. J. Masonry Constr.*, 3(1), 26-31, 1983.
44. GANZ, H.R. and THÜRLIMANN, B. - "Tests on the biaxial strength of masonry" (in German). Report No. 7502-3, Institute of Structural Engineering, Zurich, 1982.

45. DHANASEKAR, M., PAGE, A.W. and KLEEMAN, P.W. - The failure of brick masonry under biaxial stresses, *Proc. Intsn. Civ. Engrs.*, Part 2, 79, 295-313, 1985.
46. GUGGISBERG, R. and THÜRLIMANN, B. - “*Experimental determination of masonry strength parameters*” (in German). Report No. 7502-5, Institute of Structural Engineering, Zurich, 1987.
47. LURATI, F. and THÜRLIMANN, B. - “*Tests in concrete masonry walls*” (in German). Report No. 8401-3, Institute of Structural Engineering, Zurich, 1990.
48. PAGE, A.W. - Finite element model for masonry, *J. Struc. Div.*, ASCE, 104(8), 1267-1285, 1978.
49. SAADEGHVAZIRI, M.A. and METHA, S.S. - ‘An analytical model for URM structures’, Proc. 6th North American Masonry Conf., Ed. A.A. Hamid and H.G. Harris, Philadelphia, Pennsylvania, 409-418, 1993.
50. GAMBAROTTA and L., LAGOMARSINO, S. (1994), ‘Modelling unreinforced brick masonry walls’, Proc. US-Italy Workshop on guidelines for seismic evaluation and rehabilitation of unreinforced masonry buildings, Pavia, 4-17:4-29, 1994.
51. LOFTI, H.R., SHING, P.B. - Interface model applied to fracture of masonry structures, *J. Struct. Engrg.*, ASCE, 120(1), 63-80, 1994.
52. MASIA, M.J., KLEEMAN, P.W. - ‘A numerical model for cracking in masonry for use in reliability modelling’, Proc. 8th Canadian Masonry Symp., Ed. A.E. Elwi and M.A. Hatzinikolas, Jasper, Alberta, 84-95, 1998.
53. DIALER, C. - ‘A distinct element approach for the deformation behaviour of shear stressed masonry panels’, Proc. 6th Canadian Masonry Symp., Ed. V.V. Neis, Saskatoon, Saskatchewan, 765-776, 1992.
54. VERMELTFOORT, A.T., RAIJMAKERS, T.M.J., JANSSEN, H.J.M. - ‘Shear tests on masonry walls’, Proc. 6th North American Masonry Conf., Ed. A.A. Hamid and H.G. Harris, Philadelphia, Pennsylvania, 1183-1193, 1993.
55. LOURENÇO, P.B., ROTS, J.G. - A multi-surface interface model for the analysis of masonry structures, *J. Engrg. Mech.*, ASCE, 123(7), 660-668, 1997.
56. SEIM, W. - “*Numerical modeling of the failure of biaxially loaded masonry walls with consideration of anisotropy*” (in German). Ph.D. Dissertation, University of Karlsruhe, Karlsruhe, 1994.
57. LOURENÇO, P.B., BORST, R. DE, ROTS, J.G. (1997) - A plane stress softening plasticity model for orthotropic materials, *Int. J. Numer. Meth. Engrg.*, 40, 4033-4057, 1997.
58. LOURENÇO, P.B., ROTS, J.G., BLAAUWENDRAAD, J. - Continuum model for masonry: Parameter estimation and validation, *J. Struct. Engrg.*, ASCE, 124(6), 642-652, 1998.
59. LOURENÇO, P.B. - “*An anisotropic macro-model for masonry plates and shells: Implementation and validation*”. Report No. 03.21.1.3.07, Delft University of Technology, Delft, 1997.
60. LOURENÇO, P.B., “*Computational strategies for masonry structures*”. Ph.D. Dissertation, Delft University of Technology, Delft, 1996.
61. HENDRIKS, M.A.N., ROTS, J.G. and STAALDUINEN, P.C. VAN - Confidential report (in Dutch). Report no. 95-CON-R0343, TNO-Bouw, Delft, 1995.